



Standard Design
And
Construction Specifications
For Electric Systems

May 2024

33540 Loop Road
PO Box 247
Kirkwood, CA 95646
(209) 258-4444

May 8, 2024

Table of Contents

| | |
|-------------------------------------------------------------------------------|-----------|
| 1. GENERAL DESIGN CRITERIA | 4 |
| 1.1. Introduction | 4 |
| 1.2. Intent of Criteria..... | 4 |
| 1.3. Current Standards | 4 |
| 1.4. Phase and Voltage Specifications | 4 |
| 1.4.1. Standard Voltages | 4 |
| 1.4.2. Single-phase Service | 5 |
| 1.4.3. Three-phase Service..... | 5 |
| 1.5. Motor Protection and Equipment | 6 |
| 1.5.1. Allowable Motor Starting Currents | 6 |
| 1.6. Electric System Design – Sub-Transmission Lines | 6 |
| 1.6.1. Design Conditions..... | 6 |
| 1.6.2. Material..... | 7 |
| 1.7. Electric System Design – Distribution Lines | 7 |
| 1.7.1. Design Conditions..... | 7 |
| 1.7.2. Material..... | 7 |
| 1.8. Electric System Design – Service Lines | 8 |
| 1.8.1. Design Conditions..... | 8 |
| 1.8.2. Material..... | 8 |
| 1.9. Phase Rotation..... | 8 |
| 1.10. Voltage Limits..... | 8 |
| 1.11. Applicant-Owned Protective Equipment | 9 |
| 1.12. Power Factor | 9 |
| 1.13. Wave Form..... | 9 |
| 1.14. Customer-Owned Emergency Generators | 10 |
| 1.15. Customer-Owned Parallel Generation | 10 |
| 1.16. Electric Meter Requirements | 10 |
| 1.16.1. Access | 10 |
| 1.16.2. Meter Set Locations | 10 |
| 1.17. Temporary Service | 10 |
| 1.18. Electric System Layout Requirements | 10 |
| 1.18.1. Electric Line Locations and Clearances | 10 |
| 1.18.2. Sectionalizing Equipment..... | 11 |
| 2. CONSTRUCTION SPECIFICATIONS | 12 |
| 2.1. Conductor..... | 12 |
| 2.1.1. Sub-Transmission Conductor..... | 12 |
| 2.1.2. Distribution Conductor | 12 |
| 2.1.3. Service Line Conductor..... | 12 |
| 2.1.4. Limitation on Number of Service Entrance Conductors per Building | 12 |
| 2.1.5. Conductor Installation | 13 |
| 2.2. Conduit..... | 13 |
| 2.2.1. Sub-Transmission Conduit..... | 13 |
| 2.2.2. Distribution Conduit..... | 13 |
| 2.2.3. Service Line Conduit..... | 13 |
| 2.3. Pull Boxes | 13 |
| 2.4. Bus Duct..... | 14 |

| | | |
|-----------|---------------------------------------------------------------|-----------|
| 2.5. | Customer's Service Equipment | 14 |
| 2.6. | Sectionalizing Equipment | 14 |
| 2.6.1. | Sectionalizing Cabinets..... | 14 |
| 2.6.1. | Vaults..... | 14 |
| 2.6.2. | Transformer and Switch Pads..... | 15 |
| 2.6.3. | Transformers | 15 |
| 2.6.4. | Switches | 18 |
| 2.7. | Locator Tape | 18 |
| 2.8. | Pad-Mounted Equipment Screen | 18 |
| 2.9. | Metering Facilities | 19 |
| 2.9.1. | General..... | 19 |
| 2.9.2. | Residential Meters | 19 |
| 2.9.3. | Non-Residential Meters | 20 |
| 2.9.4. | Sub-Meters | 20 |
| 2.9.5. | Types of Metering Facilities | 20 |
| 2.9.6. | Facility Tampering..... | 21 |
| 2.9.7. | Meter Set Locations | 21 |
| 2.9.8. | Meter Height | 22 |
| 2.9.9. | Meter Working Space | 22 |
| 2.9.10. | Remote Read Meters..... | 22 |
| 2.10. | Meter Rooms..... | 22 |
| 2.10.1. | General Requirements..... | 23 |
| 2.11. | Laying of Conduit | 23 |
| 2.12. | Connections to Existing Electric System | 24 |
| 2.13. | Abandonment of Existing Facilities..... | 24 |
| 2.14. | Pre-Service Testing..... | 24 |
| 3. | BORING, JACKING AND TUNNELING FOR ELECTRIC LINES | 25 |
| 3.1. | Casing | 25 |
| 3.2. | Jacking and Receiving Pits..... | 25 |
| 3.3. | Alignment Tolerances..... | 25 |
| 3.4. | Rotary Drilling..... | 26 |
| 3.5. | Electric Conduit | 26 |

General Design Criteria

1. General Design Criteria

1.1. Introduction

The following design criteria shall be used for electric systems to be incorporated into the District's service area and shall govern the design of all Kirkwood Meadows Public Utility District ("KMPUD" or "District") electric facilities. Exceptions and deviations from these specifications must be approved in writing by KMPUD.

1.2. Intent of Criteria

The intent of these criteria is to ensure that the electric system constructed will dependably deliver electricity throughout the system at the least overall cost.

Electric utilities shall be designed to meet or exceed the lifespan, or depreciation period, listed in the KMPUD Asset Life Schedule (KMPUD Policy Statement 370).

KMPUD is committed to providing environmentally responsible services, therefore, all proposed installations shall be evaluated to ensure that the installation is environmentally sustainable and resource efficient throughout the life cycle of the system.

1.3. Current Standards

Applicable ordinances, rules, and regulations of all federal, state, and local agencies shall be complied with.

1.4. Phase and Voltage Specifications

Alternating current service of approximately 60-cycle frequency will be supplied

1.4.1. Standard Voltages

A. Sub-Transmission Voltages

The District operates a sub-transmission line of 34.5kV. When absolutely necessary, and at the sole discretion of the District, the District may consider supplying a customer from lines of sub-transmission voltage.

B. Distribution Voltages

The District operates a distribution system of 12.47kV.

C. Service Line Voltages

Standard Service Voltage is the voltage supplied to the consumer's Connected Load. The typical Service Voltage for Electric Service that is available is listed below. All customer-owned equipment must be designed and rated in accordance with the following utilization voltages specified by the American National Standard C84.1 if customer equipment is to give satisfactory performance:

| Normal Utilization Voltage | Minimum Utilization Voltage | Maximum Utilization Voltage |
|-------------------------------|--------------------------------|--------------------------------|
| 120 | 110 | 125 |
| 208 | 191 | 216 |
| 240 | 220 | 250 |
| 277 | 254 | 289 |
| 480 | 440 | 500 |

The differences between the service and utilization voltages are for voltage drop in customer wiring and District operations.

1.4.2. Single-phase Service

A. For 120-volt services the maximum connected load allowed is (5kVA) one 15 amp plus one 20-amp branch circuit. The maximum motor allowed is a 1-1/2 hp motor.

B. For 120/208-volt services the maximum connected load is (15kVA) a 400-amp main switch. Where the District maintains 4-wire wye-connected service, the single-phase service shall be limited to a 100-amp main switch.

C. For 120/240-volt services the maximum connected load is (75kVA) a 400-amp main switch. The maximum motor load allowed is a 10-hp motor.

1.4.3. Three-phase Service

A. The minimum connected load requirement for three-phase service is dependent on the nature, capacity, and availability of the District's facilities at any specific location.

B. Loads on three-phase service must be balanced between phases in accordance with good engineering practices, as determined by the District. In no cases will the load on any one phase exceed twice that on any other phase.

C. Loads in excess of the above stated loads may be served at the District's sole discretion. The District shall determine all necessary requirements to ensure the integrity, safety and durability of excessive loads.

D. District Authority to Modify Specifications
The District may modify the voltage and phase specification due to service conditions at the location involved.

E. District Authority to Limit Motor Size
The District may limit the size and other characteristics, of motors that may be operated in any part of its system.

F. District Authority to Limit Electric Vehicle (EV) Charging Station Size

The District may limit the size, and other characteristics of EV charging stations that may be operated in any part of its system.

G. District Authority to Require an Interruptible Load Agreement

The District may, at its sole discretion, require an Interruptible Load Agreement for new load connections that, in the determination of the District, cannot be satisfactorily served with Emergency Backup Generation.

1.5. Motor Protection and Equipment

Customer's motor equipment must conform to the following requirements:

1. Motors and related equipment shall be equipped by the customer to avoid any damage due to power outages and restorations of service, power surges, or high or low voltage fluctuations.
2. Motors shall be equipped with protective equipment needed to protect against damage due to overheating.
3. Three-phase motors shall be equipped to protect against damage due to reverse-phase and open-phase conditions.

1.5.1. Allowable Motor Starting Currents

The starting current drawn from the District's lines shall be considered the nameplate locked rotor current, or that guaranteed by the manufacturer. At its option, the District may determine the starting current by test, using a stop ammeter with not more than fifteen percent (15%) over swing; or an oscillograph disregarding the value shown for the first ten (10) cycles subsequent to energizing the motor.

The maximum connected load by service voltage in the above sections shall include, in the case of motor load, the starting current drawn from the District in addition to all other load.

At the District's sole discretion, the customer may be required, at the customer's expense, to install reduced voltage starting or other suitable means that limit the starting current to any motor.

1.6. Electric System Design – Sub-Transmission Lines

All installations are to be as shown in Kirkwood Meadows Public Utility District's Standard Drawings. Conductor and conduit of the sub-transmission line shall meet all the requirements of Sections 1.2 & 1.3 for material and installation.

1.6.1. Design Conditions

- Depth of cover to be minimum forty-eight inches (48"). The depth of burial shall be sufficient to protect the duct from damage imposed by expected surface usage.
- Minimum trench width shall be one conduit outside diameter plus eight inches (8") on either side of the pipe, and a maximum of one conduit outside diameter plus thirty-six inches (36") unless otherwise approved by KMPUD.
- Trench compaction to meet the requirements of Standard Drawing KME002.

1.6.2. Material

1.6.2.1. Conductor

Conductor for sub-transmission lines shall be 35kV, 500 kcmil compressed aluminum 345 mil TRXLPE Cable, or approved equal. The cable will include a concentric neutral (1/3 neutral) and meet all the requirements of Section 2.1. Conductor shall be continuous run with no splices.

1.6.2.2. Conduit

Conduit shall be four-inch (4") Schedule 40 PVC for single conductors and eight-inch (8") Schedule 40 PVC for three conductors in accordance with Section 2.2.

1.7. Electric System Design – Distribution Lines

All installations are to be as shown in Kirkwood Meadows Public Utility District's Standard Drawings. Conductor and conduit of the distribution line shall meet all the requirements of Sections 1.2 & 1.3 for material and installation.

1.7.1. Design Conditions

- Depth of cover to be minimum forty-eight inches (48"). Reduced cover may be allowed upon approval from KMPUD.
- Minimum trench width shall be one conduit outside diameter plus eight inches (8") on either side of the conduit, and a maximum of one pipe outside diameter plus thirty-six inches (36") unless otherwise approved by KMPUD.
- Bedding tamped to twelve inches (12") above conduit, load factor 1.5.
- Soil density one hundred thirty-five pounds per cubic foot (135 lb/cf).
- Bedding angle ninety (90) degrees.
- Live load AASHTO H-20, sixteen-thousand pound (16,000 lbs.) wheel load.

1.7.2. Material

1.7.2.1. Conductor

Conductor for electric distribution mains shall be 15kV, 2/0 Copper, 220 Mil, with a Tape Shield Concentric Neutral and meet all the requirements of Section 2.1. Conductor shall be continuous run with no splices. In specific cases, the District may require larger cable if needed to meet anticipated future loads.

1.7.2.2. Conduit

Conduit shall be four-inch (4") Schedule 40 PVC for single conductors and six-inch (6") Schedule 40 PVC for three conductors in accordance with Section 2.2.

1.8. Electric System Design – Service Lines

The electric service line is the line between the building served and the service connection. Conductor and conduit of the service line shall meet all the requirements of Sections 1.2 & 1.3 for material and installation.

1.8.1. Design Conditions

- Depth of cover to be minimum thirty-six inches (36").
- Minimum trench width shall be one pipe outside diameter plus eight inches (8") on either side of the conduit, and a maximum of one conduit outside diameter plus thirty-six inches (36") unless otherwise approved by KMPUD.
- Bedding tamped to twelve inches (12") above conduit, load factor 1.5.
- Soil density one hundred thirty-five pounds per cubic foot (135 lb/cf).
- Bedding angle ninety (90) degrees.
- Live load AASHTO H-20, sixteen-thousand pound (16,000 lbs.) wheel load.

1.8.2. Material

1.8.2.1. Conductor

Electric service line conductor shall be 4/0-4/0-2/0 Triplex or Quadriplex Aluminum Conductor 600v URD and meet all requirements of Section 2.1. Conductor shall be continuous run with no splices. . In specific cases, the District may require larger cable if needed to meet the needs of the service.

1.8.2.2. Conduit

Conduit shall be three-inch (3") Schedule 40 PVC in accordance with Section 2.2. The District may require larger conduits if a larger conductor is required.

1.9. Phase Rotation

KMPUD will maintain the three-phase rotation on existing service upon upgrade or reconnection of its system. The phase rotation for new services will be determined by KMPUD.

1.10. Voltage Limits

KMPUD will maintain the voltage at a level in accordance with common industry practice.

Some examples of exceptions:

- Disturbance from acts of nature
- Infrequent Momentary Voltage Fluctuations

- Service Interruptions
- Temporary Isolation of parts of the distribution system due to faults or routine maintenance work
- Other causes beyond the control of KMPUD, including degradation or failure of customer equipment
- Distribution equipment and material failures
- Starting of motors that have higher than normal locked rotor currents of three times running current
- Temporary heavy load conditions

Customer's system should be designed and operated to maintain a reasonably balanced load between phases to maintain balanced voltage. KMPUD reserves the right to require the Customer to correct the unbalance in their load that causes an increase of more than one percent (1%) in the voltage unbalance of the supply system.

1.11. Applicant-Owned Protective Equipment

KMPUD's electric system can be affected adversely when an applicant's equipment causes voltage or frequency fluctuations. In the case of hoist or elevator motors, welders, furnaces, compressors, electric heaters, and other installations of similar characteristics, where the use of electricity is intermittent or subject to violent fluctuations, KMPUD may require the applicant to install, at their expense, any equipment necessary to mitigate or eliminate these detrimental effects. KMPUD, and the appropriate Federal, State, or County jurisdictional authorities as may be applicable (e.g. County Building Inspector, CalOSHA, etc.), must review and approve these installations before initiating electric service. Applicants must add any necessary protective equipment when their operations change and those changes could create any of the three adverse conditions described herein. KMPUD may terminate service and refuse to restore that service to any applicant who continues to operate without the proper protective equipment after receiving notification from KMPUD. Applicants are responsible for damages made to KMPUD equipment because they did not install the proper protective equipment.

1.12. Power Factor

The District may require the customer to provide, at the customer's expense, equipment to increase the operating power factor at the District's service connection point to the customer to not less than ninety-five percent (95%), lagging or leading.

The District, at its sole discretion, shall be authorized to install kVAR metering for kW metering where the customer is, in the District's opinion, of sufficient size and may have a power factor such that billing in this manner is appropriate.

1.13. Wave Form

The District may require that the waveform of current drawn by customer equipment of any kind be in conformity with good engineering practices and IEEE 519.

1.14. Customer-Owned Emergency Generators

Customers desiring to install emergency generators that are capable of being connected to premises wiring will coordinate with the District during the design of such installation. An automatic or manual break-before-make transfer switch shall be installed by the Customer to prevent parallel operation of the generator and KMPUD's Electric System.

1.15. Customer-Owned Parallel Generation

The Customer shall comply with current local, state, and federal, codes, laws, and regulations governing Customer-owned generation (e.g., solar photovoltaic (PV) systems, micro turbines, wind turbines, and other on-site generation sources) that is intended to operate in parallel with KMPUD's Electric System. The Customer will coordinate with the District during design of such installation and will obtain its approval for the design. The Customer will furnish and install KMPUD-approved protection, controls and metering equipment, and will obtain the approval of the KMPUD Inspector and of the authority having jurisdiction. KMPUD will require the Customer with solar PV systems, micro turbines, or wind turbines to sign an applicable interconnection agreement, prior to interconnecting to the electric distribution system.

1.16. Electric Meter Requirements

1.16.1. Access

KMPUD employees require access to meters to perform inspection and maintenance activities. When electric meters are installed in meter rooms, an approved key lock box shall be installed near the meter room to hold a key to allow KMPUD access.

1.16.2. Meter Set Locations

Typically, KMPUD provides only one meter for each dwelling unit, installed in an outside location, and one service lateral for each building. Meter locations must comply will all requirements in Section 2.9.

1.17. Temporary Service

If a connection point is available, KMPUD will provide an estimate of the cost of labor and expendable material necessary to install and remove a temporary service. All labor and materials charges must be paid to KMPUD before temporary service is established.

1.18. Electric System Layout Requirements

1.18.1. Electric Line Locations and Clearances

Electric lines shall be placed in a roadways and public utility easements unless the District deems the alignment impractical, in which case a twenty-foot (20') easement in favor of the District is required. Electric lines shall be installed in the center of the required twenty-foot (20') easement. Locate distribution mains ten feet (10') from the face or foundation of any building. Electric lines parallel to paved roads shall be installed with a minimum of five feet (5') horizontal separation from the edge of pavement.

Unless otherwise approved by the District, all electric locations shall not interfere with other existing utilities. All parallel and crossing utilities shall follow KMPUD Standards (KMW011 and KMW011A).

The National Electrical Safety Code specifies certain requirements for the general safety of the public. Should any person or party cause the facilities of the Association to be in violation of these requirements, the District will cause all activity to cease in relation to these violations until remedial action can be taken. The cost of the remedial action will be presented to the person or party responsible for payment, and payment must be made before the activity may resume.

Electric service lines proposed to run under or through retaining structures or under or through structures, buildings, foundations or decks will require approval by the District. Written justification will be required. If approved, the electric service line under or through retaining structures, structures, buildings foundations of decks shall require installation in a casing.

Electric distribution lines shall be looped and connected wherever possible by development, even if outside the boundaries of the development and where required by KMPUD. In all cases, electric lines shall be extended to the property lines of the development along all access roads or routes, where looping is possible, and where potential future development or connections may exist. When an area outside the development, but in reasonably close proximity as determined by KMPUD staff, can be logically served by future extension of a proposed electric line, the electric line shall extend to the tract boundary or to the end of a paved street in a manner to facilitate the future extension and include any necessary over sizing.

When an existing primary distribution loop is just sufficient to supply existing loads, it may be necessary to split the loop in order to serve a new development. In which case, the contractor will provide all underground substructures, including conduits, pull boxes, and equipment pads, required to implement the circuit splitting. Easements may be required for the new facilities.

Private or non-District facilities, service lines or other appurtenances shall not be allowed within District trench sections, without written approval from KMPUD.

1.18.2. Sectionalizing Equipment

The electric system shall be equipped with a sufficient number of sectionalizing cabinets, vaults, transformers and switches so that each street, neighborhood and commercial development can be isolated while maintaining service to the remaining distribution area. The maximum spacing between sectionalizing equipment shall not exceed one thousand feet (1000').

All sectionalizing equipment shall meet the specifications in Section 2.6.

Technical Standards

2. Construction Specifications

2.1. Conductor

All conductor shall be installed in conduit per the specifications in Section 2.2. Conductor ends shall be sealed in an approved manner to prevent moisture from entering the cable prior to termination

2.1.1. Sub-Transmission Conductor

Sub-transmission conductor shall be 35kV, 500 kcmil compressed aluminum 345 mil TRXLPE Cable, in accordance with ICEA S-94-649-2004 and ASTM B-231, or approved equal. The cable will include a concentric neutral (1/3 neutral). The minimum insulation thickness shall not be less than 330 mils and the maximum insulation thickness shall not be more than 375 mils.

2.1.2. Distribution Conductor

Distribution conductor shall be UL listed Medium-Voltage Power Cable, 15kV, 2/0 copper, 220 Mills, with tape shield concentric neutral. Southwire Simpull NL - EPR TYP MV 105 or approved equal.

2.1.3. Service Line Conductor

Service line conductors will be UL listed as cross-linked polyethylene insulation for 600 volts. Minimum service size will be 100 amperes. Service conductors for commercial and industrial buildings shall be copper. For conductor sizes above 500 kcmil, the Customer will provide connectors as approved by KMPUD. Aluminum conductors are acceptable for residential building services only.

Service conductors shall have phase identifying color tape and service address identification using permanent markers.

2.1.4. Limitation on Number of Service Entrance Conductors per Building

Per CEC 230-2, KMPUD will allow only one set of Service Entrance Conductors per voltage classification per building unless otherwise approved by KMPUD or the authority having jurisdiction.

2.1.5. Conductor Installation

All conductor installation shall be witnessed by KMPUD. Pulling tension on conductors shall not exceed IEEE recommended practice.

2.2. Conduit

All electric conduit shall be polyvinyl chloride (PVC) Schedule 40, UL-listed, in twenty-foot (20') lengths with molded couplings. Couplings shall be approximately two times the conduit diameter in length. Conduit lengths and bends shall be connected using cement (glue) recommended by the conduit manufacturer and approved by KMPUD.

Plastic conduit bends shall be long radius sixty-inch (60") minimum. A forty-eight inch (48") bending radius may be allowed under special circumstances with prior approval from KMPUD. KMPUD will allow a thirty-six inch (36") bending radius for three-inch (3") and four-inch (4") conduits and a forty-eight inch (48") bending radius for six-inch (6") and eight-inch (8") conduits; respectively, entering equipment pads. A maximum of 270° total bends is allowed in any conduit run. Installations with total bends exceeding 270° will require pull boxes as determined by KMPUD.

All conduits left clear without conductors shall be provided with a 2,500 lb. lubricated pull tape, with waterproof footage markings for measuring. ARNCO lubricated Dandy-line CAT# ARC-L40-2500, or its approved equivalent shall be used. Conduit installed in vaults shall extend into the vault a minimum of two inches (2"). Conduit installed for pad-mounted equipment shall terminate within the window, above grade even with the top of the pad. Conduit shall be aligned to permit a straight pull through boxes. All conduit left clear without conductors in a vault, pad or box shall have blank expansion duct plugs of the appropriate size installed with a rope tie.

Any conduit installed for future use shall have a KMPUD approved pull box at the termination point.

2.2.1. Sub-Transmission Conduit

Conduit for 34.5kV sub-transmission lines shall be four-inch (4") Schedule 40 PVC for single conductors and eight-inch (8") Schedule PVC for three conductors in accordance with standard drawing U0-1.

2.2.2. Distribution Conduit

Conduit for 12.47kV distribution lines shall be four-inch (4") Schedule 40 PVC for single conductors and six-inch (6") Schedule PVC for three conductors.

2.2.3. Service Line Conduit

Conduit for service lines shall be three-inch (3") Schedule 40 PVC.

2.3. Pull Boxes

A pull box is an enclosure used to facilitate pulling high voltage distribution conductor or low voltage secondary conductor and may or may not contain cable splices or equipment. Pull boxes shall be located as required to maintain acceptable pulling

tensions. Conduit shall enter the pull box at the knock-out or at the KMPUD-designated location on the side of the box. Each conduit termination shall extend not more than 1-inch into the secondary pull box and shall have an end bell. The bottom of each conduit shall be at least two inches (2") from the bottom of the box. After the installation of the conduit into the primary pull box, all box openings and joints shall be sealed with high strength, quick-set grout, SikaGrout 212 or approved equal, both inside and outside the box to prevent the entrance of water and sand into the box. The grouting of openings must be approved by the KMPUD Inspector. Wherever possible, primary pull box bottom shall be placed on undisturbed soil. If this not possible, compaction beneath the box shall be a minimum of 90% in six-inch (6") layers.

2.4. Bus Duct

For secondary services larger than 3,000 Amperes up to 4,000 Amperes, KMPUD will require the customer to provide and install a copper bus duct per the applicable electrical code. The bus duct shall be sized based on the current density at 1000A/square inch. The customer will retain ownership and will be responsible for the maintenance of the bus duct. The customer shall coordinate with KMPUD if transformer switching is required to facilitate bus duct maintenance.

2.5. Customer's Service Equipment

The Customer or developer will furnish and install Electric Utility Service(s) Equipment Requirements Committee (EUSERC) compliant Service Equipment for each building. Service Equipment drawing submittal will be required for KMPUD approval for all Services larger than 200 Amperes.

Service Equipment, switchboard bus and secondary service bus sizes will be rated based on the following current density: 1,000 amperes per square inch for copper bus and 750 Amperes per square inch for aluminum bus.

2.6. Sectionalizing Equipment

2.6.1. Sectionalizing Cabinets

Sectionalizing cabinets shall be designed as a top hinge design and shall be made of 12-gauge mild steel or aluminum with a thickness of 0.125".

Sectionalizing cabinets shall have a minimum of three (3) t-point junction interface points, as approved by KMPUD. Each junction point must be compatible with 200 Amp load break elbows for 12.47kV installations and 600 A deadbreak elbows for 34.5kV installations. A parking bushing must be provided for each phase.

2.6.1. Vaults

Electrical vaults shall be located as specified in the KMPUD-approved drawings for the project. Vaults and covers located in paved streets, alleys, or areas subject to any traffic shall be approved for H-20 traffic loading. Weight of the cover shall not exceed sixty (60) pounds per section. Covers shall have an antiskid (All grip or approved equal) finish and labeled "KIRKWOOD MEADOWS

PUD HIGH VOLTAGE” with penta-head hold-down bolts, and a galvanized steel frame adjustable to grade. Vault walls shall be manufactured with galvanized Unistrut channel and cast-in end bells for PVC Schedule 40 conduit, as approved by KMPUD. The vault shall have two (2) pulling irons on each wall in line with the conduit entry and two feet from the top for lengthwise pulling and four (4) pulling irons on the floor at the designated locations. The pulling iron shall have an ultimate strength of twenty-thousand pounds (20,000 lbs).

Vaults shall be installed one half inch (1/2”) below grade in paved areas and one inch (1”) above grade in unpaved areas. A minimum of twelve inches (12”) of 4-inch (4”) thick concrete around the outside edge of the vault, with a #4 reinforcing bar on all four sides of the vaults, rounded rebar corners and tied together is required irrespective of location,

Install a five-eighths by eight inch (5/8” X 8”) copper grounding rod and #1/0 copper ground wire per standard drawing KME011. No ground rod shall be installed through the vault sump hole.

All electrical conduit in the vault shall be terminated with expansion end bells. After the conduit has been installed, all openings and joints shall be sealed with high-strength quick-set grout, SikaGrout 212 or approved equal, and made watertight with particular attention and care taken not to rough up the end bell surface over which the conductors are pulled. Where required, removable and reusable expansion duct plug water-tight to thirty (30) psi shall be provided.

Upon completion of installation, each vault shall be cleaned of all debris and sand. Each vault cover frame shall be bolted to the vault wall and cover plates, or lid shall be bolted down with penta-head bolts.

2.6.2. Transformer and Switch Pads

Each transformer and/or switch pad shall meet the requirements of standard drawing KME009 and KME010. The transformer and switch pad shall comply with the KMPUD minimum clearance requirements. The exact location and dimensions of each transformer and/or switch pad and the location and number of conduits and number of conduits entering the pad shall be determined, inspected, and approved by KMPUD.

2.6.3. Transformers

Transformers shall be pad-mounted, mineral oil immersed and self-cooled. All transformers shall be designed for outdoor application at altitudes of 7,800 feet above sea level, in an ambient not exceeding 35°C maximum, and average ambient for any 24-hour period not exceeding 25°C.

Transformer paint finish total film thickness applied shall be 3.0 MIL thickness as determined by testing per V.P.A. Technology MINIDERM S-100A standard.

Certified test data shall be supplied upon request demonstrating compliance with the following parameters:

- The paint finish shall be capable of passing a 1500 hours Salt Spray test per ASTM B117 and Federal Specification TT-P-141 with no blistering and passing method 6061 with less than 1/16" underfilm present.
- The paint finish shall be capable of passing an 850-hour Humidity test with 98% relative humidity at 45 to 50°C with no blistering.
- The paint finish shall be capable of passing a cross-hatch-type adhesion test.
- The paint finish shall be capable of passing oil resistance tests of 3 days immersion at room temperature and three (3) days immersion at 100°C with no apparent effect.
- Paint color standard forest green (Munsell green 7GY or ANSI equivalent color).

Accessories for the transformer shall include a fill plug and drain valve with sampler device. Bayonet-type fuse holder(s) for oil immersed, dual sensing expulsion fuses(s) shall be provided. The Bayonet device shall be rated to make or break full load current rating of the transformer. A high-voltage bushing, a non-conducting drip shield shall be provided. Fuses shall be included at time of order. A durable metal nameplate made of stainless steel or anodized aluminum material and conforming to ANSI/IEEE C57.12.00 shall be affixed to each transformer and contain all essential data, year of manufacture, serial number, and clearly state insulating oil is NON-PCB.

Each equipment enclosure shall display a "WARNING" sign placed so that it is visible to anyone attempting entry to the enclosure. Also, the equipment inside the enclosure shall display a "DANGER" sign in both primary and secondary compartments so that it is visible when the enclosure is open.

The noise level for each transformer shall not exceed ANSI standards for distribution class transformers.

2.6.3.1. Losses

All transformers shall be tested for no load and full load losses, and percent impedance. Certified test data shall be provided for each transformer shipped. Full losses shall be tested for at 65°. The actual core loss and total loss parameters of transformers received shall not exceed the quoted parameters by more than the following:

- Core Loss (Excitation or No Load) + 10%
- Total Loss (Full Load Loss) + 6%

2.6.3.2. Single Phase Transformers

All single-phase transformers shall be top-hinge, low profile design, 60 Hz, mineral-oil filled, pad mounted, compartment type distribution transformers, with separable insulated high voltage connectors rated 12470/7200Y.

The transformer shall have a hinged compartment door and sill arrangement to provide access to the terminating compartment. Stainless steel (alloy 304L) hinges shall be provided. The stainless steel hinge pins shall be a minimum of 3/8" in diameter. The hinges shall be continuously welded to the tank and lid. The gauge of the hinges is to be the same as or greater than the gauge of the door.

In addition to the regular locking provisions, all access doors or hood shall be secured by a recessed, captive, pentahead bolt and padlock provisions. Equipment shall meet the requirements for tamper resistance as set forth in ANSI C57.12.28

Lifting inserts shall be of corrosion resistant material and so arranged to provide a suitable balance lift for the completely assembled unit. Lifting bolts shall be supplied with each unit.

Tanks without cooling fins are preferred. If required, cooling fins shall be designed so that no sharp points or edges exist on any part of the fins or where they attach to the tank. External corners and edges shall be rounded and smoothed. Cooling fins shall be arranged to minimize their protrusion from the tank.

The high voltage side shall include bushing wells and 200-amp load break bushing inserts. The service voltage side shall include compression type two-hole crimp lugs.

2.6.3.3. Three Phase Transformers

All three-phase transformers shall be approved by KMPUD during the design phase.

Three-phase transformers shall have full height, air-filled terminal compartments with hinged doors shall be located side by side. The doors shall be attached with stainless steel hinges and hinge pins and incorporate a threepoint latching mechanism operated by the low voltage door handle, with doorstops on both doors to secure doors during servicing. To facilitate making connections and permit cable pulling, the doors and compartment hood shall be removable. A removable doorsill shall be provided to permit rolling or skidding unit into place over conduit stub-ups in foundation.

The incoming compartment shall be on the left and shall be accessible only after the door to the outgoing compartment has been opened. The

incoming compartment shall enclose the high voltage bushings and provide for incoming cable from below.

The outgoing line compartment shall be on the right side and arranged for cabling from below. Three line bushings and the neutral bushing shall be supplied with spade type terminations with standard NEMA spacing and drilling. Provide one insulated neutral bushing with an externally removable ground strap.

Transformer primary and secondary coil and core assembly shall be copper windings.

The Low Voltage Compartment shall include externally clamped low voltage bushings with threaded copper studs and NEMA 8-hole rotatable spades.

The High Voltage Compartment shall include:

- a. Dead-front construction with 200 amp bushing inserts, suitable for loop feed.
- b. Bayonet Fuses
- c. Ground pad
- d. De-energized tap changer

2.6.3.4. Transformer Sizing

Transformer sizing will be determined by KMPUD based on number of units and electric load calculations. Electric load calculations shall be submitted during the design phase of the project.

For commercial installations or high-density condominiums, transformer sizing will be determined by KMPUD based on number of units and electric load calculations. Electric load calculations shall be submitted during the design phase of the project.

2.6.4. Switches

Switches shall be designed by a California registered Professional Engineer and reviewed for approval by KMPUD. District staff should be consulted in the early planning stages to assess the need for such installations and to develop the site-specific design criteria, which shall be determined solely by the District.

2.7. Locator Tape

All electric lines shall be marked with a three inch (3") red metallic locator tape, located twelve inches (12") directly above the pipe and bedding material. The tape shall be marked with one and a half inch (1½") black "CAUTION – Electric LINE BURIED BELOW" lettering and be placed face up in the trench.

2.8. Pad-Mounted Equipment Screen

To minimize the visual impact of its equipment, KMPUD may approve the installation of aesthetic screens around its pad-mounted equipment. Screens shall be placed such that there are no obstructions within the easement in which pad-mounted equipment is installed, nor within eight (8) feet, whichever is more greater from the equipment.

Screens may be in the form of landscaping, retaining walls or decorative walls. Screens shall be installed, owned and maintained by the customer. Screens shall not impair the maintainability and operability of KMPUD's electrical equipment. Gates or doors may be placed on wall screens as long as a minimum eight-foot (8') clearance is available with the gates and doors open. Decorative walls or fences are not substitutes to any required barrier posts or bollards.

All equipment screens shall be subject to approval by KMPUD.

2.9. Metering Facilities

2.9.1. General

- a. The applicant, or customer, shall, at their sole liability, risk and expense, be responsible to furnish, install, own, maintain, inspect, and keep in good and safe condition, all facilities of any kind or character on applicant's or customer's premises that are not the responsibility of the District but are required for the applicant or customer to receive service. Such equipment shall include but not be limited to termination equipment, conduits, conductors and all equipment within all buildings, connectors, meter bases and sockets, relays, meter and instrument transformer housing, service switches, circuit breakers, fuses, wire ways, metered conductors, machinery and apparatus of any kind or character
- b. The applicant is responsible for the installation of a meter base that meets the District's standards and that will accommodate a District meter(s).
- c. The District will meter the delivery of all electric power and energy, unless otherwise provided for in the District's rules and regulations.
- d. All District meters and associated metering equipment shall be located at an accessible protected location on the applicant's premises as approved by the District. Installations inside single-family residences are not allowed.
- e. The load served at each meter location will be clearly designated by the customer. Load served behind one meter may not be transferred to be served by another meter unless the customer has received prior District approval

2.9.2. Residential Meters

Electric service shall be individually metered to every residential unit in a residential building or group of buildings or other development with multiple tenants such as, but not limited to, condominiums and commercial buildings.

The District will normally install only one meter for each premises except:

- When required by law or local ordinance; or,
- When additional services are granted by the District.

2.9.2.1. Multiple Occupancy

In a building with two or more tenants, or where more than one meter is used on the same Premises, the meters normally shall be grouped at one central location, or as otherwise specified by the District, and each meter position or socket shall be clearly and permanently marked by Applicant, customer, or owner of the premises to indicate the particular unit, occupancy, or load supplied by it.

2.9.3. Non-Residential Meters

Electric service shall be individually metered to each tenant in a non-residential building or group of buildings or other development on a single Premises with multiple tenants or enterprises (such as, but not limited to, an office building or shopping center complex).

2.9.3.1. Service Disconnects

All 480-volt services shall have a single main disconnect. All other services 800 amps or larger shall also have a single main disconnect.

2.9.4. Sub-Meters

Sub-meters shall not be allowed for billing purposes. Sub-meters may be installed by the customer for non-revenue purposes after the KMPUD meter, upon approval of KMPUD.

2.9.5. Types of Metering Facilities

2.9.5.1. Up to 200 Amp - Less Than 600 Volts, Line-to-Line

The Customer will provide the socket for self-contained meter. For three phase service, Customer will furnish and install a bussed safety socket with factory installed test by-pass facilities for self-contained metering. All the metering equipment will be supplied by the customer except for the KMPUD supplied meter.

KMPUD will not accept new metering facilities with lever-operated by-pass meter sockets. Upon upgrade or modification of any existing metering facility with lever-operated by-pass meter socket, it will be upgraded to the current standard at the customer's cost.

2.9.5.2. Over 200 Amp and less than 4000 Amp – Less than 600 Volts, Line-to-Line

Transformer-rated metering facilities will be required and provided by the Customer. All the metering equipment will be supplied by the customer except for the KMPUD supplied current transformer, test switches and meter.

2.9.5.3. Over 600 Volts, Line-to-Line

All electric services greater than 4,000 Amperes at 480 volts will be served and metered at primary voltage. The design drawing of the service equipment will be submitted to KMPUD for approval prior to installation. KMPUD will provide all current and potential transformers and wires to the test switches needed for metering. KMPUD will provide the meter and test switch.

2.9.6. Facility Tampering

The applicant or customer shall provide a suitable means acceptable to the District for placing District's seals on meter rings and covers of service enclosures and instrument enclosures that protect unmetered and energized conductors. Only District authorized employees shall be authorized to break such seals once installed. However, in an emergency the District may allow a public authority or other appropriate party to break the seal. Any unauthorized tampering with District seals or connection of applicant or customer owned facilities to unmetered conductors is prohibited and is subject to discontinuance of service and other appropriate actions.

2.9.7. Meter Set Locations

Typically, KMPUD provides only one meter for each dwelling unit, installed in an outside location, and one service lateral for each building. Approved meter set locations are:

- A. Meters for low density condominiums (2-3 dwelling units per building) shall be co-located in a single location per building.
- B. Meters for high density condominiums (more than 4 dwelling units per building) shall be co-located in one or more locations as approved by KMPUD.
- C. Meter set located outside in an enclosure or an alcove meeting the requirements of KMPUD Ordinance 21-01, or subsequent Ordinances as may be amended from time to time. See KMPUD standard drawing KME005. The enclosure may require a custom design depending on the configuration.

- D. Meter set located inside a building in an electric meter room. Electric meter rooms will be approved by KMPUD on a case-by-case basis and must meet the requirements in Sections 2.9.4, 2.9.5 and 2.10.

2.9.8. Meter Height

Meter shall meet the following installation height requirements:

- A. Individual field-installed meter panels shall be mounted at a minimum height of forty-eight inches (48") and a maximum height of sixty-six inches (66") measured from the centerline of the meter to the standing surface.
- B. Multiple meter panel assemblies or switchboard structures shall be mounted at a minimum height of thirty-six inches (36") and a maximum height of seventy-five inches (75") measured from the centerline of the meter to the standing surface.

2.9.9. Meter Working Space

A level standing surface with a clear and unobstructed working space above must be provided and maintained in front of each metering installation. The working space must have a width of not less than thirty-six inches (36") and a minimum height of seventy-five inches (75") for individual meter panels. Seventy-eight inch (78") minimum height from standing surface is required for all other installations. The working space must extend at least thirty-six inches (36") in front of the surface on which the metering equipment is mounted. There shall be at least ten inches (10") from the meter centerline to any side obstruction and at least nine inches (9") from the meter centerline to any obstruction above the meter. Working space requirements shall be in accordance with CEC 110-26.

2.9.10. Remote Read Meters

Most KMPUD electric meters are equipped with a remote read system that uses radio frequency (RF) technology to transmit meter reads automatically. To ensure that the remote read system can operate properly:

- A. Meters shall not be located in any room, cabinet, enclosure, or configuration that blocks or interferes with the RF signal transmissions.
- B. Meters shall not be located within six inches (6") to any metallic object that could block or interfere with the RF signal transmission.
- C. Meters shall not be located within five feet (5') of building walls and/or ceilings if they are made from a significant amount of metal or metal reinforcements.

2.10. Meter Rooms

It is the responsibility of the applicant to design, construct, and furnish the electric meter room and related materials to meet the electric meter room requirements that are described in these Specifications, and in accordance with the California Building Code.

2.10.1. General Requirements

Outdoor meter locations are preferred. When meters are located within a building, adequate illumination with a switch located by the entry shall be provided. The room shall be directly accessible from the exterior of the building. If entry is lockable, a key must be provided to KMPUD prior to energizing the service. Use if the meter room or enclosure for other than metering, electrical service equipment will not be permitted without KMPUD's approval. Meter room shall not be used for storage of any kind.

Meter(s) shall be located as close as practicable to the point of entry of the conductors into the building. The following are unacceptable meter room locations:

1. On any floor other than the ground floor in buildings with four stories or fewer.
2. In any place where moisture, fumes or dust may interfere with meter operation or materially damage the meter.
3. In a hazardous location.

2.11. Installation of Conduit

Conduit trenching and/or excavations shall not be permitted until the site has been brought to finish grade or the roadway has been brought to subgrade.

Conduit shall be installed and joined in accordance with the manufacturer's and/or KMPUD Inspector's directions, whichever is more stringent. Necessary facilities including slings shall be provided for lowering and properly placing pipe sections into the trench without damage.

Each section of conduit shall be thoroughly cleaned before it is lowered into the trench. If clean conduit sections cannot be placed in the trench without getting foreign material into open pipe, the KMPUD Inspector may require protection of the ends of the conduit until it has been lowered into position in the trench. After the conduit has been lowered into the trench, all foreign matter shall be completely removed from the conduit before assembly.

The conduit shall be laid to the lines and grades specified on the plans and centered in the trench. The alignment and elevation of the pipeline as shown on the drawings shall be designed to avoid conflict with new and existing underground utilities.

Trenches must be kept dry until conduit has been laid, joints closed and backfill completed to a depth of one foot (1') above top of conduit. Crushed rock for drainage and/or bedding shall be provided, as necessary.

2.12. Connections to Existing Electric System

All connections to the existing electric system shall be made as shown on the plans and in accordance with these Specifications.

Connection to the existing electric system will be made at a transformer, vault, switch or sectionalizing cabinet. All energized electric work will be performed by KMPUD staff.

When deemed necessary by the KMPUD Inspector, shutdowns of existing in-service equipment shall be made by the District as required to complete electric connections. A shutdown shall be for as short a period as necessary for shutdown and connection to existing equipment, this varies with each job and must be planned accordingly. Unless dictated by electric system consideration, or emergencies, in no case will a shutdown and/or connection be scheduled with less than ten (10) days' notice. Interference with the operation of the District's electric system shall be kept at a minimum. While existing electric equipment is de-energized, the connection work shall be performed without interruption, continuing after regular working hours if necessary, until completed, unless otherwise directed by the KMPUD Inspector. In some cases, shutdowns must occur at times other than normal working hours and/or days. Shutdowns shall not be scheduled Fridays through Mondays. All costs for labor and equipment shall be the responsibility of the Contractor.

In all cases, shutdowns shall be made under the direction of the KMPUD Inspector. The District shall open and close all in-service electric equipment, as well as perform required hot work required to initiate service to the new installation.

The KMPUD Inspector shall be notified at least ten (10) working days prior to any connection so that advance preparation on the part of the District can be made and shall confirm such advance notice in writing. In no case shall any connection operations occur prior to passing pre-service tests.

2.13. Abandonment of Existing Facilities

Existing facilities shall be abandoned as indicated on the plans and specifications. Pad-mounted equipment to be abandoned shall be removed, along with the concrete pad, and the vault shall be backfilled to the specifications on standard drawing KME002.

2.14. Pre-Service Testing

The KMPUD Inspector shall be notified forty-eight (48) hours prior to testing. All testing shall occur in the presence of a KMPUD Inspector or be subject to re-testing or rejection.

All new conductor shall require a continuity test and insulation strength test prior to being placed in service. A high-voltage withstand test shall be performed on each phase at very-low-frequency (VLF) for 60 minutes. The test voltage for 12.47kV conductor is 21 kV (RMS) [30kV Peak] at 0.1Hz (minimum). The voltage waveform should be either cosine-rectangular or sinusoidal. Testing requirements for 35kV conductor shall be approved by KMPUD.

A failure during testing will require that the failed sections of conductor be replaced and retested successfully before energization

3. Boring, Jacking and Tunneling for Electric Lines

3.1. Casing

KMPUD must approve all requests for electric service in a casing before installation. Allowable casings for electric conduit shall be HDPE casing material, imprinted with "ELECTRIC SLEEVE." Alternate casings may be permitted upon approval of KMPUD. Casing shall be of a size to permit installation and removal of the electric conduit. State highway casing installations shall be as specified in the California Department of Transportation specifications.

Casing shall be sized based on the following:

| Electric Conduit (IPS) (inches) | Minimum Casing Size (inches) |
|----------------------------------------|-------------------------------------|
| 2 | 4 |
| 3 | 6 |
| 4 | 8 |
| 6 | 12 |
| 8 | 16 |

3.2. Jacking and Receiving Pits

The distance from the edge of the pavement to each end of the bore shall be ten feet (10') or five feet (5') beyond the outside toe of the slope. Jacking and Receiving Pits shall conform to these specifications. Where Jacking and Receiving Pits are within Caltrans or County right-of way, it shall be subject to their requirements.

All boring, jacking, and receiving pits shall be:

- A. located at least ten feet (10') from edge of pavement on conventional highways in rural areas; and
- B. located five feet (5') outside toe of slope in embankment areas; and
- C. adequately protected with fencing and/or type "K" barriers; fence shall be a minimum of six foot (6') high, in panel sections, securely fastened together with reflectors secured to the side of the fence that faces the traffic. Partially buried posts with fencing attached to form a continuous fence, with reflectors secured to the side of the fence that faces traffic may also be used; and
- D. adequately shored in accordance with Cal/OSHA or FED-OSHA.

3.3. Alignment Tolerances

The centerline of the casing shall not vary in line or grade from the desired alignment by more than one percent (1%) or one foot (1') per hundred feet (100') of casing.

3.4. Rotary Drilling

The face must be mechanically cut (not cut with fluid pressure); the water must be mixed with bentonite, as required by ground conditions; the fluid must be supplied to the face from a controlled tank; under no circumstances shall the fluid line be hooked directly to the water system or the water truck while drilling; the controlled tank must be able to mix and agitate the fluid; the controlled tank must also be capable of regulating volume and pressure; and the fluid mix shall be used only for lubrication and to bring back cuttings, not to cut the face. This method can be used for various sizes, lengths and ground conditions.

3.5. Electric Conduit

Electric conduit installed in casing shall meet the requirements of Section 2.2. All casing installations shall be installed with red tracer wire, Soft Drawn No. 12 insulated.

ELECTRIC STANDARD DETAILS

LIST OF FIGURES

| | |
|---------|--------------------------------------------------------|
| KME001 | ELECTRIC GENERAL NOTES |
| KME002 | TRENCH BEDDING AND BACKFILL LOW VOLTAGE SECONDARIES |
| KME003 | TRENCH BEDDING AND BACKFILL HIGH VOLTAGE PRIMARY |
| KME004 | JOINT TRENCH DETAIL LOW VOLTAGE SECONDARIES |
| KME005 | ELECTRIC METER COVER |
| KME005A | ELECTRIC METER COVER ALTERNATE |
| KME006 | TYPICAL UNDERGROUND SERVICE |
| KME007 | CLEARANCE REQUIREMENTS FOR PADMOUNT EQUIPMENT |
| KME008 | MINIMUM CLEARANCE REQUIREMENTS FOR VAULTS |
| KME009 | THREE-PHASE PRECAST CONCRETE TRANSFORMER PAD |
| KME010 | SINGLE-PHASE PRECAST CONCRETE TRANSFORMER PAD |
| KME011 | GROUNDING REQUIREMENTS FOR PRECAST CONCRETE VAULTS |
| KME012 | PRECAST CONCRETE VAULT LAYOUT |



ELECTRIC STANDARD DETAILS

| | | |
|---------------|------------------|----------------------------------|
| DATE: 5/5/22 | APPROVED BY: BB | DRAWING NUMBER: KME000 |
| SCALE: N.T.S. | DRAWN BY: L.P.B. | |

GENERAL NOTES:

- 1) THE TYPES, LOCATIONS, SIZES, AND DEPTHS OF EXISTING UNDERGROUND UTILITIES AS SHOWN ON THESE IMPROVEMENT PLANS WERE OBTAINED FROM SOURCES OF VARYING RELIABILITY AND ARE APPROXIMATE. A REASONABLE EFFORT HAS BEEN MADE TO LOCATE AND DELINEATE ALL KNOWN UNDERGROUND FACILITIES. HOWEVER, THE ENGINEER CAN ASSUME NO RESPONSIBILITY FOR THE COMPLETENESS OR ACCURACY OF THE DELINEATION OF SUCH UNDERGROUND FACILITIES, NOR THE EXISTENCE OF OTHER BURIED OBJECTS OR FACILITIES WHICH MAY BE ENCOUNTERED BUT WHICH ARE NOT SHOWN ON THE DRAWINGS. THE CONTRACTOR SHALL BE RESPONSIBLE FOR PROTECTING THE EXISTING UTILITIES, WHETHER SHOWN OR NOT SHOWN ON THE DRAWINGS AND TO FIELD VERIFY THE EXACT LOCATION OF ALL EXISTING UTILITIES. THE CONTRACTOR SHALL EXPOSE ALL UNDERGROUND FACILITIES THAT ARE TO BE CONNECTED TO OR THAT ARE IN THE PATH OF THE PROPOSED IMPROVEMENTS FOR VERIFICATION OF LOCATION AND ELEVATION PRIOR TO THE COMMENCING OF CONSTRUCTION. THE CONTRACTOR SHALL BE RESPONSIBLE FOR CONSTRUCTING THE ELECTRIC LINE AND APPURTENANCES PER THE IMPROVEMENT PLANS DESPITE THE PRESENCE OF BURIED OBJECTS OR FACILITIES WHICH WERE NOT EXPECTED TO BE ENCOUNTERED, AND THE CONTRACTOR SHALL NOT BE REIMBURSED FOR ANY EXPENSES BROUGHT UPON BY SUCH BURIED OBJECTS OR UTILITIES. THE CONTRACTOR OR ANY SUBCONTRACTOR SHALL NOTIFY UNDERGROUND SERVICES ALERT (USA) AT 811 IN ACCORDANCE WITH THE SPECIFICATIONS PRIOR TO ALL EXCAVATION.
- 2) THE CONTRACTOR SHALL CONTACT THE KIRKWOOD MEADOWS PUBLIC UTILITY DISTRICT ("KMPUD") AT (209)258-4444 48 HOURS OR TWO (2) BUSINESS DAYS, WHICHEVER IS GREATER, PRIOR TO COMMENCEMENT OF THE PRE-CONSTRUCTION MEETING AND INITIAL ELECTRIC LINE CONSTRUCTION, AND TWENTY-FOUR HOURS PRIOR TO EACH DAY WORK ON ELECTRIC LINE INSTALLATION OCCURS.
- 3) ALL WORK SHALL BE PERFORMED IN ACCORDANCE WITH THE MOST CURRENT KMPUD STANDARDS AND "STANDARD SPECIFICATIONS OF THE STATE OF CALIFORNIA, DEPARTMENT OF TRANSPORTATION". WHERE THERE IS ANY CONFLICT, KMPUD STANDARDS SHALL PREVAIL.
- 4) THE CONTRACTOR SHALL TAKE ALL PRECAUTIONARY MEASURES NECESSARY TO PROTECT EXISTING IMPROVEMENTS THAT ARE TO REMAIN IN PLACE. ALL IMPROVEMENTS DAMAGED BY THE CONTRACTOR'S OPERATIONS SHALL BE EXPEDITIOUSLY REPAIRED OR RECONSTRUCTED AT THE CONTRACTOR'S EXPENSE AND INSPECTED BY THE AGENCY OR CONTROLLING AGENCY, WITHOUT ADDITIONAL COMPENSATION.
- 5) ELECTRIC SUB-TRANSMISSION LINES AND DISTRIBUTION LINES SHALL HAVE 48-INCHES MINIMUM COVER EXCEPT WHERE SPECIFICALLY NOTED ON THE PROJECT PLANS. 36-INCHES TO 48-INCHES OF COVER MAY REQUIRE RED DYED 2 SACK SAND SLURRY BACKFILL, SUBJECT TO KMPUD APPROVAL. LESS THAN 36-INCHES OF COVER WILL NOT BE ALLOWED UNDER ANY CIRCUMSTANCES.
- 6) CONDUIT BENDS AND TIE IN DETAILS INDICATED ON THE PLANS ARE APPROXIMATE HORIZONTAL ANGLES AND ARE INTENDED TO SHOW THE ESSENTIAL ELEMENTS REQUIRED OF THE CONNECTION. ACTUAL FIELD LAYOUT MAY BE DIFFERENT. A MAXIMUM OF 270 DEGREES OF TOTAL BENDS ARE ALLOWED ON ANY CONDUIT RUN. INSTALLATIONS WITH TOTAL BENDS EXCEEDING 270 DEGREES WILL REQUIRE PULL BOXES AS DETERMINED BY KMPUD. THE CONTRACTOR SHALL SUPPLY ALL LABOR, STANDARD OR FABRICATED FITTINGS, AND APPURTENANCES REQUIRED FOR THE BEND OR TIE-IN INSTALLATION, WITH NO ADDITIONAL REIMBURSEMENT. THE CONTRACTOR SHALL SUBMIT SHOP DRAWINGS FOR ALL CUSTOM FABRICATED FITTINGS.
- 7) THE CONTRACTOR SHALL PROVIDE THE LABOR AND MATERIALS REQUIRED FOR CONTINUITY AND INSULATION STRENGTH TESTING. ALL TESTING SHALL BE OBSERVED AND ACCEPTED BY KMPUD. ACTUAL CONNECTIONS TO EXISTING KMPUD ELECTRIC EQUIPMENT WILL NOT BE PERMITTED PRIOR TO THE COMPLETION AND ACCEPTANCE OF PRE-SERVICE TESTING. KMPUD PERSONNEL SHALL OPEN AND CLOSE ALL IN-SERVICE ELECTRIC EQUIPMENT AND PERFORM REQUIRED HOT WORK REQUIRED TO INITIATE SERVICE TO THE NEW INSTALLATION.
- 8) THE CONTRACTOR SHALL BE RESPONSIBLE FOR MAINTAINING RECORD DRAWINGS FOR ALL WORK THROUGHOUT THE COURSE OF CONSTRUCTION. SUCH DRAWINGS SHALL RECORD THE LOCATION AND GRADE OF ALL UNDERGROUND IMPROVEMENTS CONSTRUCTED AND SHALL BE DELIVERED TO KMPUD PRIOR TO, AND IN CONSIDERATION OF KMPUD'S ACCEPTANCE OF WORK.
- 9) THE CONTRACTOR SHALL REMOVE AND PROPERLY DISPOSE OF ALL SURPLUS EXCAVATION MATERIAL AND DEBRIS PROMPTLY FROM THE SITE AND SHALL MAINTAIN THE SITE IN A NEAT AND ORDERLY CONDITION. THE CONTRACTOR SHALL OBTAIN ALL NECESSARY FILL AND GRADING PERMITS.
- 10) CONTRACTOR SHALL AT ALL TIMES COMPLY WITH THE SAFETY RULES AND REGULATIONS ESTABLISHED BY CAL-OSHA AND OTHER AGENCIES HAVING JURISDICTION OVER THE WORK AND SHALL BE REQUIRED TO OBTAIN ALL PERMITS. CONTRACTOR SHALL ASSUME SOLE AND COMPLETE RESPONSIBILITY FOR JOB SITE CONDITIONS DURING THE COURSE OF CONSTRUCTION OF THIS PROJECT, INCLUDING THE SAFETY OF ALL PERSONS AND PROPERTY.
- 11) ALL EXISTING IMPROVEMENTS, INCLUDING BUT NOT LIMITED TO LANDSCAPING, DRIVEWAYS, DRAINAGE DITCHES AND MONUMENTS, SHALL BE RESTORED TO THE CONDITION IN WHICH THEY WERE PRIOR TO CONSTRUCTION, OR BETTER.
- 12) A WRITTEN REQUEST TO REMOVE AND/OR TRIM ANY TREES SHALL BE SUBMITTED IN WRITING TO THE OWNER; NO REMOVAL AND/OR TRIMMING SHALL TAKE PLACE WITHOUT WRITTEN RESPONSE BY THE OWNER.
- 13) ALL TREES REQUIRING TRIMMING OR REMOVAL SHALL BE IDENTIFIED BY THE CONTRACTOR AND THE CONTRACTOR SHALL COMPLY WITH ALL KIRKWOOD TRI-TAC COMMITTEE REQUIREMENTS REGARDING TRIMMING OR REMOVAL WORK. WHERE APPROPRIATE, CONTRACTOR SHALL ALSO NOTIFY THE PROPERTY OWNER, HOMEOWNER ASSOCIATION AND KMPUD.
- 14) PLAN APPROVAL SHALL EXPIRE TWO YEARS FROM DATE OF KMPUD SIGNATURE OR CONDITIONAL WILL SERVE COMMITMENT, WHICHEVER COMES FIRST.



ELECTRIC GENERAL NOTES

| | | |
|------------------|---------------------|--------------------------------------|
| DATE: 5/5/22 | APPROVED BY: | DRAWING NUMBER: KME001 |
| SCALE: N.T.S. | DRAWN BY: L.P.B. | |

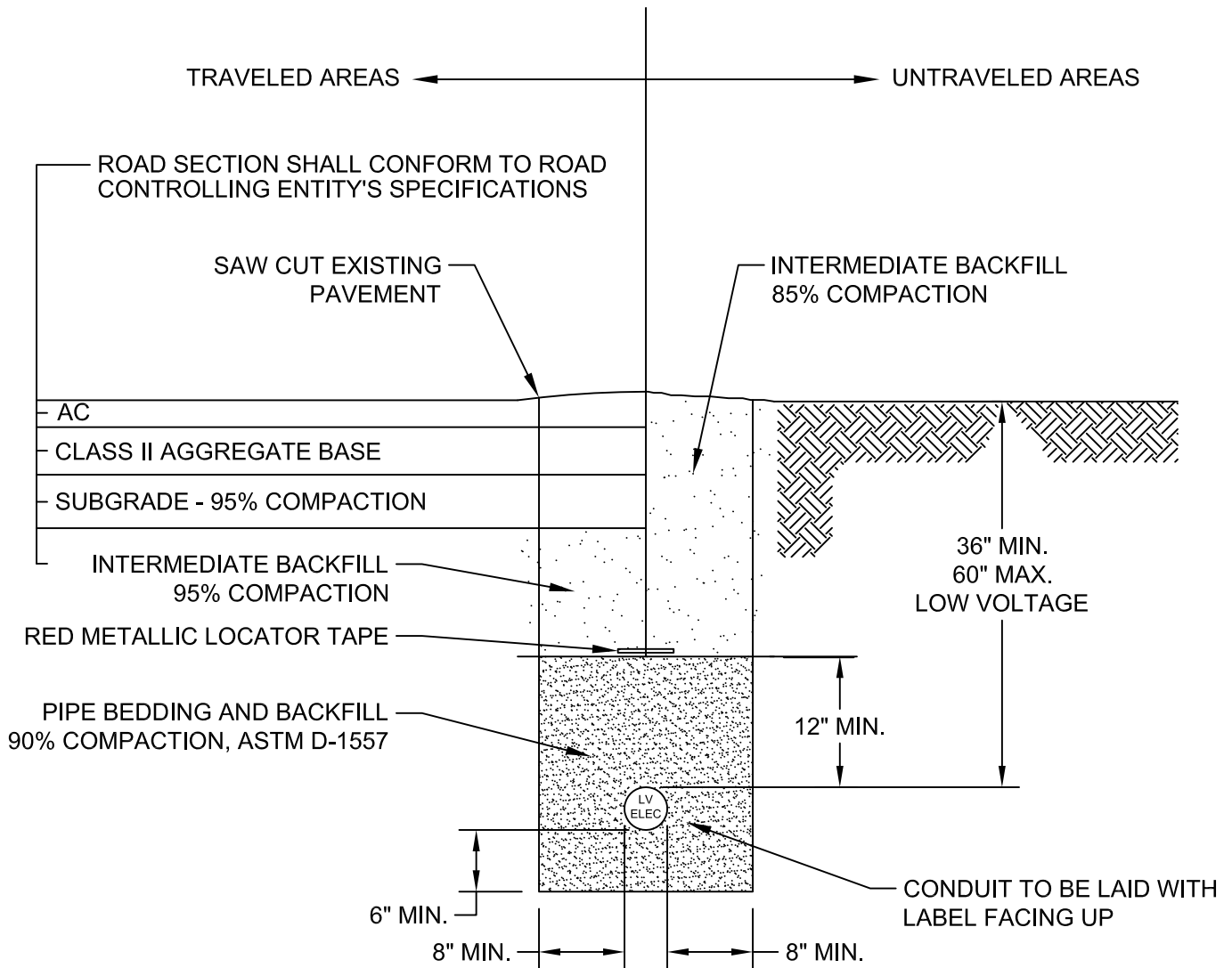

PIPE BEDDING & BACKFILL: WELL GRADED CLEAN SAND CONFORMING TO THE FOLLOWING GRADATION:

- NO. 4 SIEVE: 75-100% PASSING BY WEIGHT
- NO. 30 SIEVE: 12-60% PASSING BY WEIGHT
- NO. 100 SIEVE: 5-20% PASSING BY WEIGHT
- NO. 200 SIEVE: 0-10% PASSING BY WEIGHT

NOTES:

1. COVER MAY BE REDUCED TO 18" FOR LOW VOLTAGE ELECTRIC PROVIDED INTERMEDIATE BACKFILL CONSISTS OF 12" MIN. OF RED DYED 2 SACK SAND SLURRY. SAND ABOVE CONDUIT MAY BE REDUCED TO 6".
2. GREATER THAN 40" OF COVER FOR LOW VOLTAGE ELECTRIC MUST BE PRE-APPROVED BY KMPUD.
3. RED LOCATOR TAPE AT TOP OF SAND TO BE MARKED: "CAUTION BURIED ELECTRIC LINE BELOW".
4. INTERMEDIATE BACKFILL MAY CONSIST OF IMPORTED OR NATIVE MATERIAL WITH ALL ROCKS OR COBBLE OVER 3" REMOVED AND FREE OF VEGETATIVE MATERIAL.
5. SEE KME004 FOR JOINT TRENCH DETAIL.



**TRENCH BEDDING & BACKFILL
LOW VOLTAGE SECONDARIES**

| | | |
|------------------|------------------------|--------------------------------------|
| DATE: 4/19/22 | APPROVED BY: E.M.C. | DRAWING NUMBER: KME002 |
| SCALE: N.T.S. | DRAWN BY: L.P.B. | |

STANDARD HIGH VOLTAGE PRIMARY (PRIVATE PROPERTY OR EASEMENT)

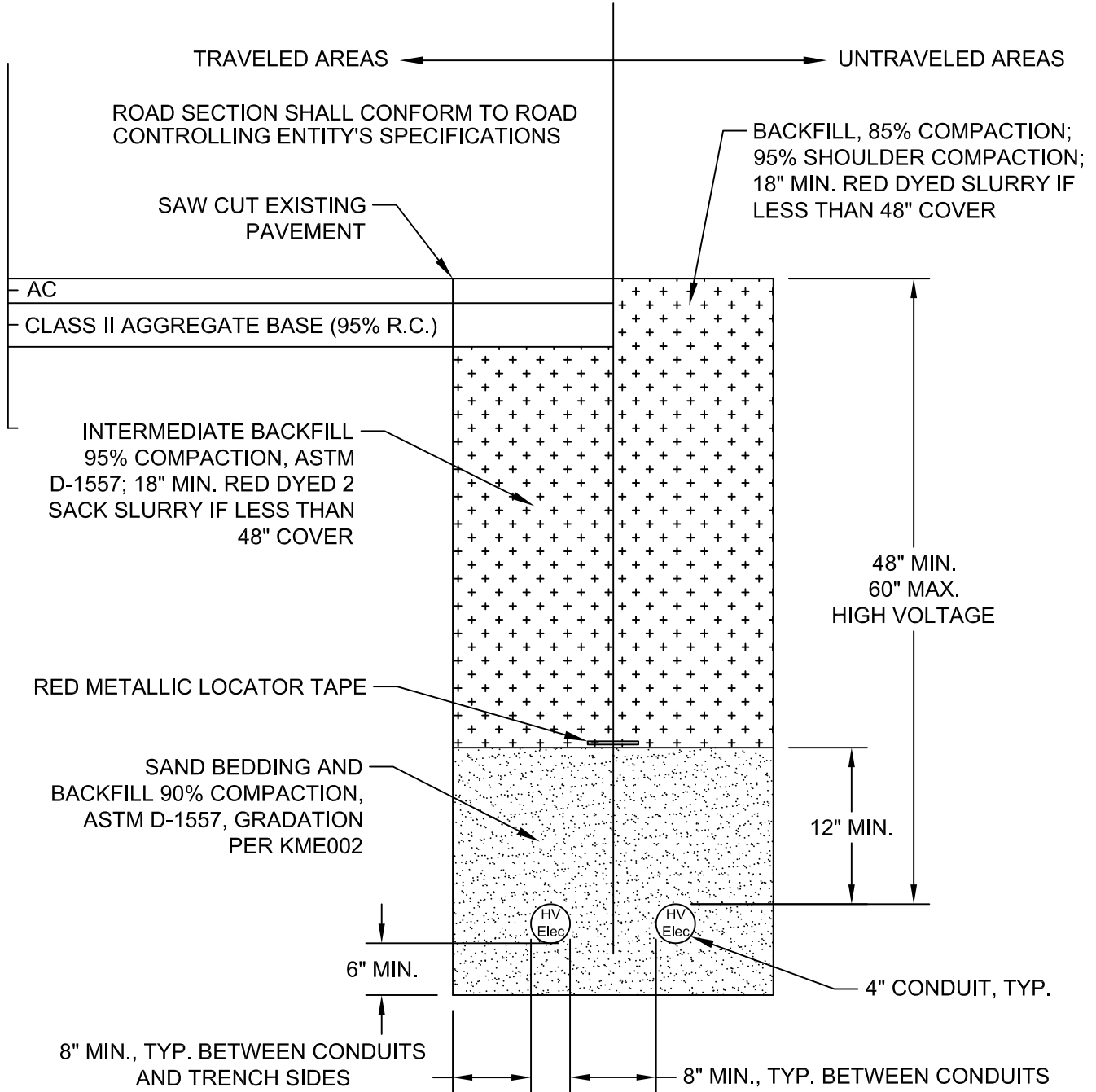

NOTES:

1. COVER MAY BE REDUCED TO 36" FOR HIGH VOLTAGE ELECTRIC PROVIDED INTERMEDIATE BACKFILL CONSISTS OF 18" MIN RED DYED 2 SACK SAND SLURRY.
2. RED LOCATOR TAPE AT TOP OF SAND TO BE MARKED: "CAUTION BURIED ELECTRIC LINE BELOW".
3. INTERMEDIATE BACKFILL MAY CONSIST OF IMPORTED OR NATIVE MATERIAL WITH ALL ROCKS OR COBBLE OVER 3" REMOVED AND FREE OF VEGETATIVE MATERIAL.
4. JOINT TRENCHES NOT PERMITTED FOR HIGH VOLTAGE PRIMARY.



TRENCH BEDDING AND BACKFILL HIGH VOLTAGE PRIMARY

| | | |
|------------------|---------------------|-----------------|
| DATE: 5/5/22 | APPROVED BY: | DRAWING NUMBER: |
| SCALE: N.T.S. | DRAWN BY: L.P.B. | KME003 |

JOINT TRENCH

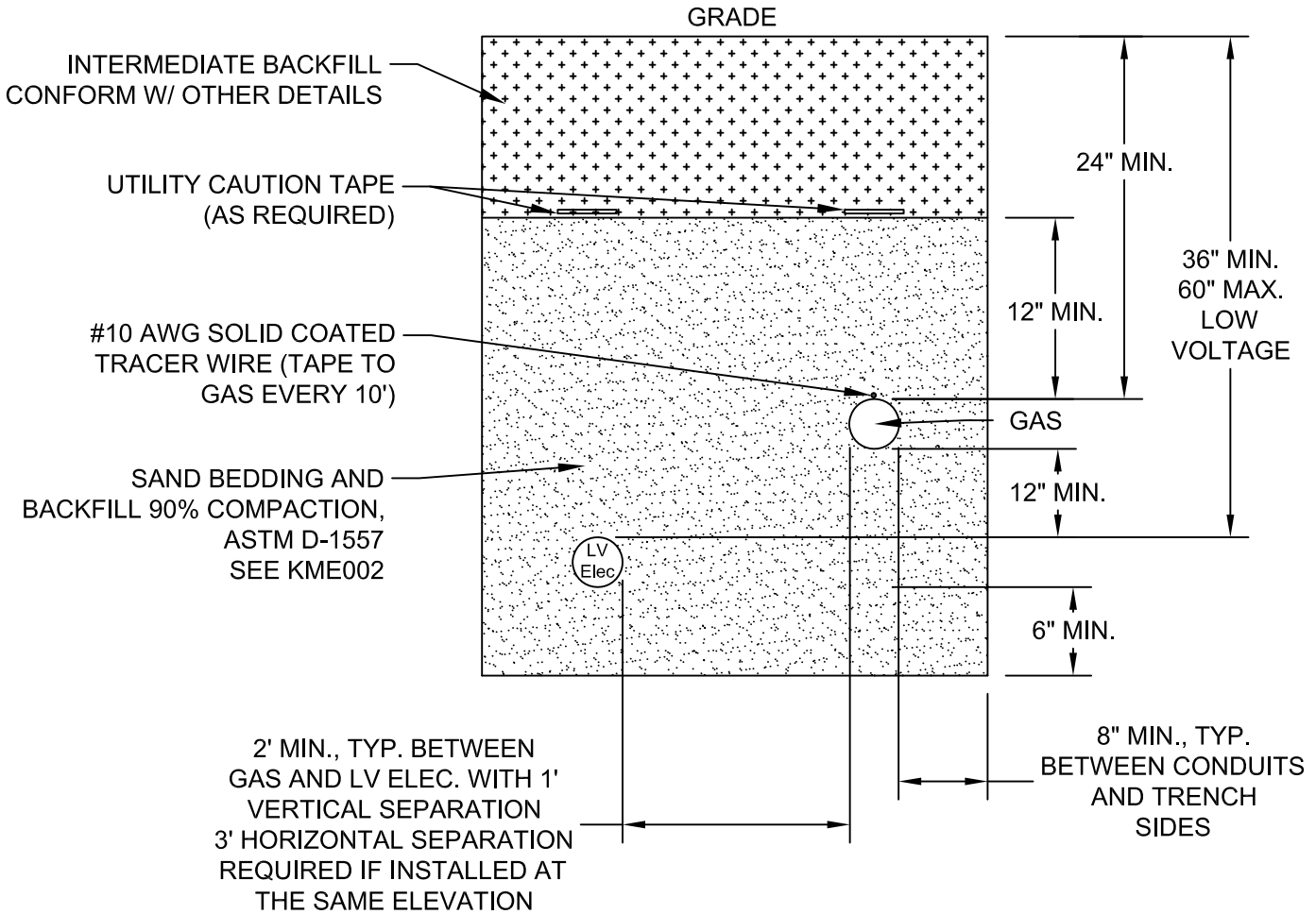

NOTES:

1. GREATER THAN 40" OF COVER FOR LOW VOLTAGE ELECTRIC MUST BE PRE-APPROVED BY KMPUD.
2. RED LOCATOR TAPE AT TOP OF SAND TO BE MARKED: "CAUTION BURIED ELECTRIC LINE BELOW".
3. PROVIDE YELLOW LOCATOR TAPE AT TOP OF SAND ABOVE GAS MARKED: "CAUTION BURIED GAS LINE BELOW". PROVIDE #10 AWG COPPER LOCATOR WIRE FOR ALL PROPANE INSTALLATIONS.



JOINT TRENCH DETAIL LOW VOLTAGE SECONDARIES

| | | |
|------------------|---------------------|-----------------|
| DATE: 5/5/22 | APPROVED BY: | DRAWING NUMBER: |
| SCALE: N.T.S. | DRAWN BY: L.P.B. | KME004 |

NOTES:

1. HOMEOWNER MAY SUBSTITUTE PRE-FABRICATED GALVANIZED STEEL ROOF STRUCTURE IF SUBMITTAL IS PROVIDED TO KMPUD DETAILING STRUCTURE AND 300 PSF SNOW LOAD CAPACITY, CERTIFIED BY MANUFACTURER OR A CALIFORNIA REGISTERED PROFESSIONAL CIVIL OR STRUCTURAL ENGINEER.
2. STRUCTURE MAY BE PAINTED, STAINED OR COVERED TO MATCH HOUSE COLOR OR STYLE.
3. ALTERNATE DESIGNS MAY BE SUBMITTED TO KMPUD AND WILL BE EVALUATED ON A CASE BY CASE BASIS.
4. PROVIDE METAL OR COMPOSITE ROOFING MATERIAL OVER ENCLOSURE ROOF PLYWOOD.
5. ANY WOOD IN CONTACT WITH CONCRETE SHALL BE PRESSURE TREATED.
6. ANCHOR QUANTITY ACCEPTABLE FOR 2,500 PSI CONCRETE AND 1,500 PSI FULLY GROUTED MASONRY. LESSER VALUES OR OPEN CELL CMU WILL REQUIRE ENGINEERING.
7. SPACE CONCRETE AND MASONRY FASTENERS EVENLY ACROSS LEDGER AND STAGGER. PROVIDE 8" MINIMUM BETWEEN FASTENERS.
8. EMBEDMENT IS INTO CONCRETE OR MASONRY OR FRAMING MEMBERS OF EXTERIOR WALL.
9. EPOXY ANCHORS OR OTHER MANUFACTURERS' ANCHORS MAY BE UTILIZED IF THEY EQUAL OR BETTER DESIGN VALUES OF ANCHOR SHOWN OR ARE SUBMITTED TO KMPUD FOR APPROVAL.
10. INSTALL ALL ANCHORS IN ACCORDANCE WITH MANUFACTURER INSTRUCTIONS.

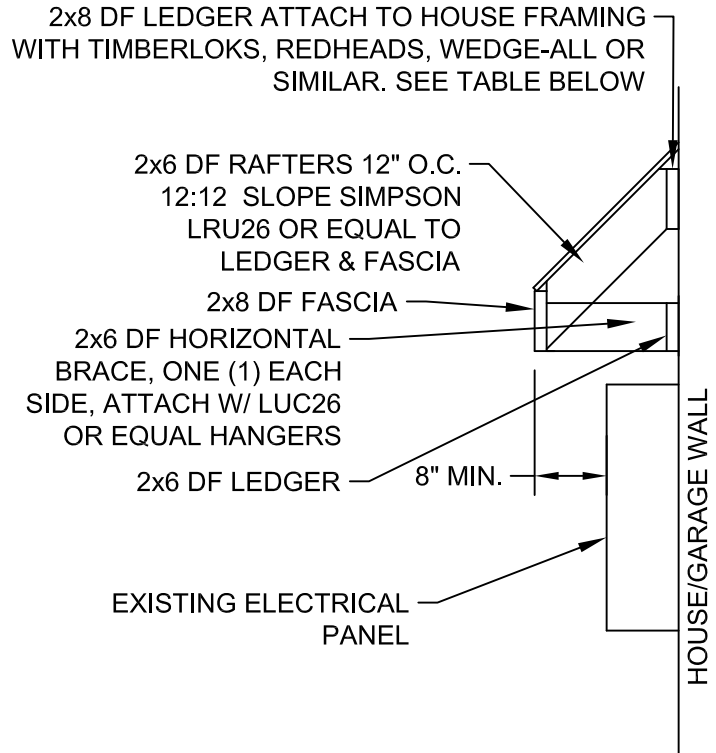

SIDE PROFILE VIEW

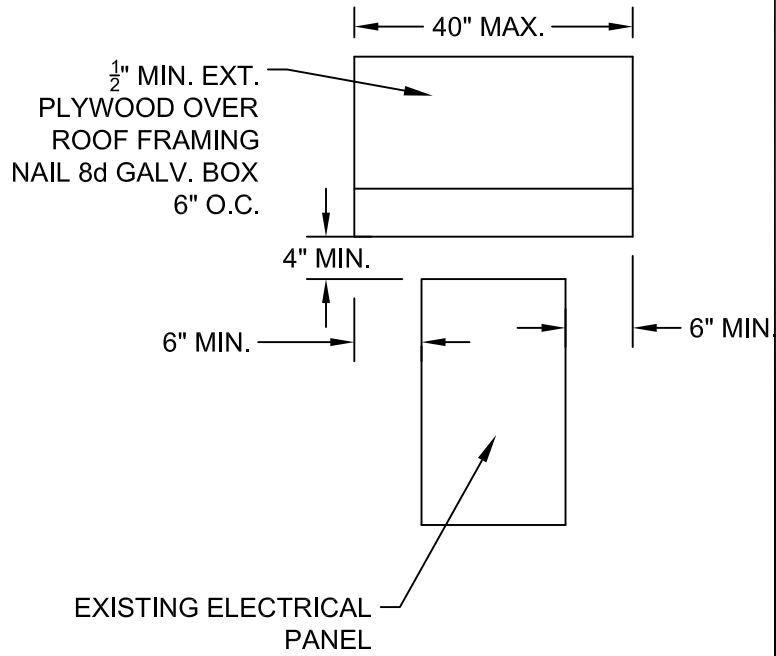

FRONT PROFILE VIEW

| FASTENER/ANCHOR | MINIMUM EMBEDMENT | # PER HORIZ. LEDGER (MIN.) |
|-------------------------------------------|-------------------|----------------------------|
| TIMBERLOK, LEDGERLOK OR SIMPSON SDS | 2-1/2" | 9 |
| 3/8" + STRONGBOLT2 OR TITEN HD - CONCRETE | 3" | 3 |
| 1/2" STRONGBOLT2 OR TITEN HD - MASONRY | 3-1/2" | 4 |
| 3/8" + WEDGE-ALL - CONCRETE | 3" | 3 |
| 1/2" WEDGE-ALL - MASONRY | 3-1/2" | 6 |



ELECTRIC METER COVER

| | | |
|---------------|------------------|----------------------------------|
| DATE: 4/19/22 | APPROVED BY: | DRAWING NUMBER: KME005 |
| SCALE: N.T.S. | DRAWN BY: L.P.B. | |

NOTES:

1. HOMEOWNER MAY SUBSTITUTE PRE-FABRICATED GALVANIZED STEEL ROOF STRUCTURE IF SUBMITTAL IS PROVIDED TO KMPUD DETAILING STRUCTURE AND 300 PSF SNOW LOAD CAPACITY, CERTIFIED BY MANUFACTURER OR A CALIFORNIA REGISTERED PROFESSIONAL CIVIL OR STRUCTURAL ENGINEER.
2. STRUCTURE MAY BE PAINTED, STAINED OR COVERED TO MATCH HOUSE COLOR OR STYLE.
3. ALTERNATE DESIGNS MAY BE SUBMITTED TO KMPUD AND WILL BE EVALUATED ON A CASE BY CASE BASIS.
4. PROVIDE METAL OR COMPOSITE ROOFING MATERIAL OVER ENCLOSURE ROOF PLYWOOD.
5. ANY WOOD IN CONTACT WITH CONCRETE SHALL BE PRESSURE TREATED.
6. ANCHOR QUANTITY ACCEPTABLE FOR 2,500 PSI CONCRETE AND 1,500 PSI FULLY GROUTED MASONRY. LESSER VALUES OR OPEN CELL CMU WILL REQUIRE ENGINEERING.
7. SPACE CONCRETE AND MASONRY FASTENERS EVENLY ACROSS LEDGER AND STAGGER. PROVIDE 8" MINIMUM BETWEEN FASTENERS.
8. EMBEDMENT IS INTO CONCRETE OR MASONRY OR FRAMING MEMBERS OF EXTERIOR WALL.
9. EPOXY ANCHORS OR OTHER MANUFACTURERS' ANCHORS MAY BE UTILIZED IF THEY EQUAL OR BETTER DESIGN VALUES OF ANCHOR SHOWN OR ARE SUBMITTED TO KMPUD FOR APPROVAL.
10. INSTALL ALL ANCHORS IN ACCORDANCE WITH MANUFACTURER INSTRUCTIONS.

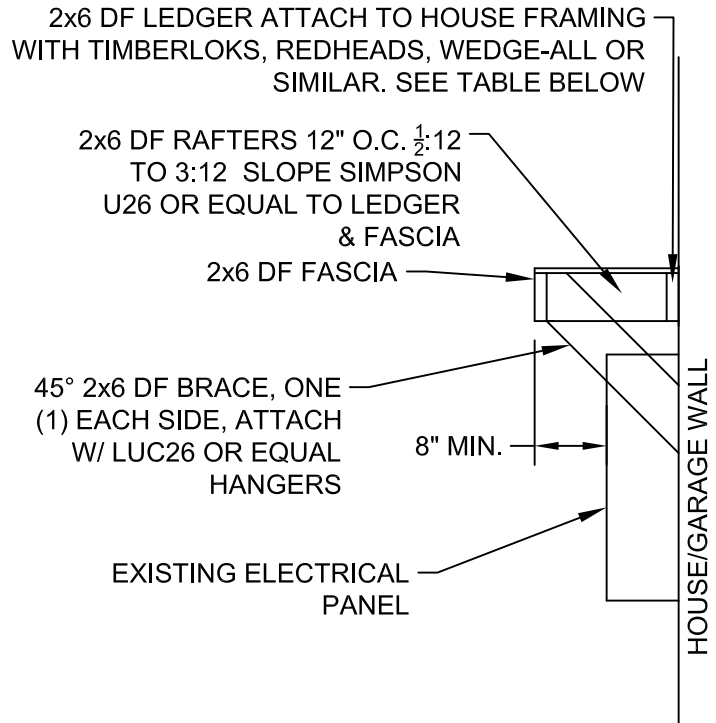

SIDE PROFILE VIEW

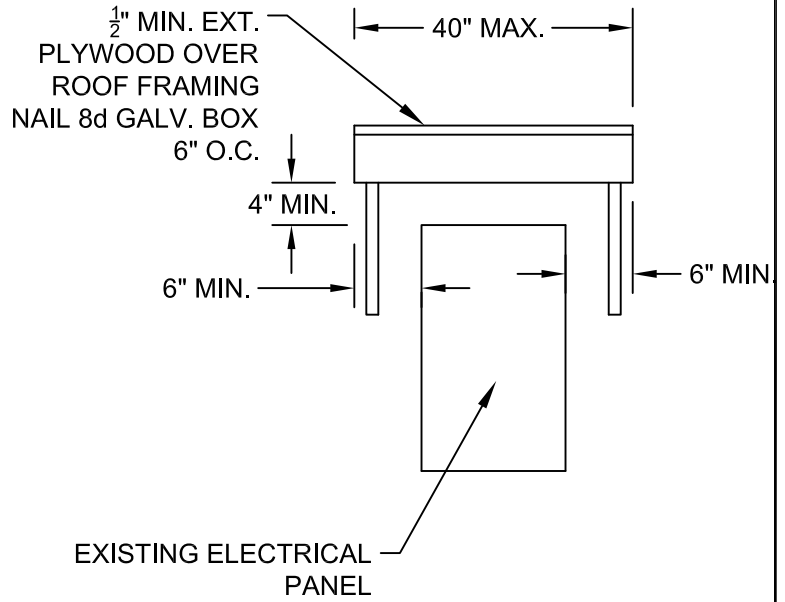

FRONT PROFILE VIEW

| FASTENER/ANCHOR | MINIMUM EMBEDMENT | # PER HORIZ. LEDGER (MIN.) |
|-------------------------------------------|-------------------|----------------------------|
| TIMBERLOK, LEDGERLOK OR SIMPSON SDS | 2-1/2" | 9 |
| 3/8" + STRONGBOLT2 OR TITEN HD - CONCRETE | 3" | 3 |
| 1/2" STRONGBOLT2 OR TITEN HD - MASONRY | 3-1/2" | 4 |
| 3/8" + WEDGE-ALL - CONCRETE | 3" | 3 |
| 1/2" WEDGE-ALL - MASONRY | 3-1/2" | 6 |



ELECTRIC METER COVER ALTERNATE

| | | |
|------------------|---------------------|---------------------------------------|
| DATE: 4/19/22 | APPROVED BY: | DRAWING NUMBER: KME005A |
| SCALE: N.T.S. | DRAWN BY: L.P.B. | |

NOTES:

1. PANEL LOCATION MUST BE APPROVED BY KMPUD.
2. GROUNDING CONDUCTOR SIZING:
 - A) 100A/125A SERVICE: #8 SOLID COPPER GROUND/BONDING
 - B) 200/225A SERVICE: #4 SOLID COPPER GROUND/BONDING

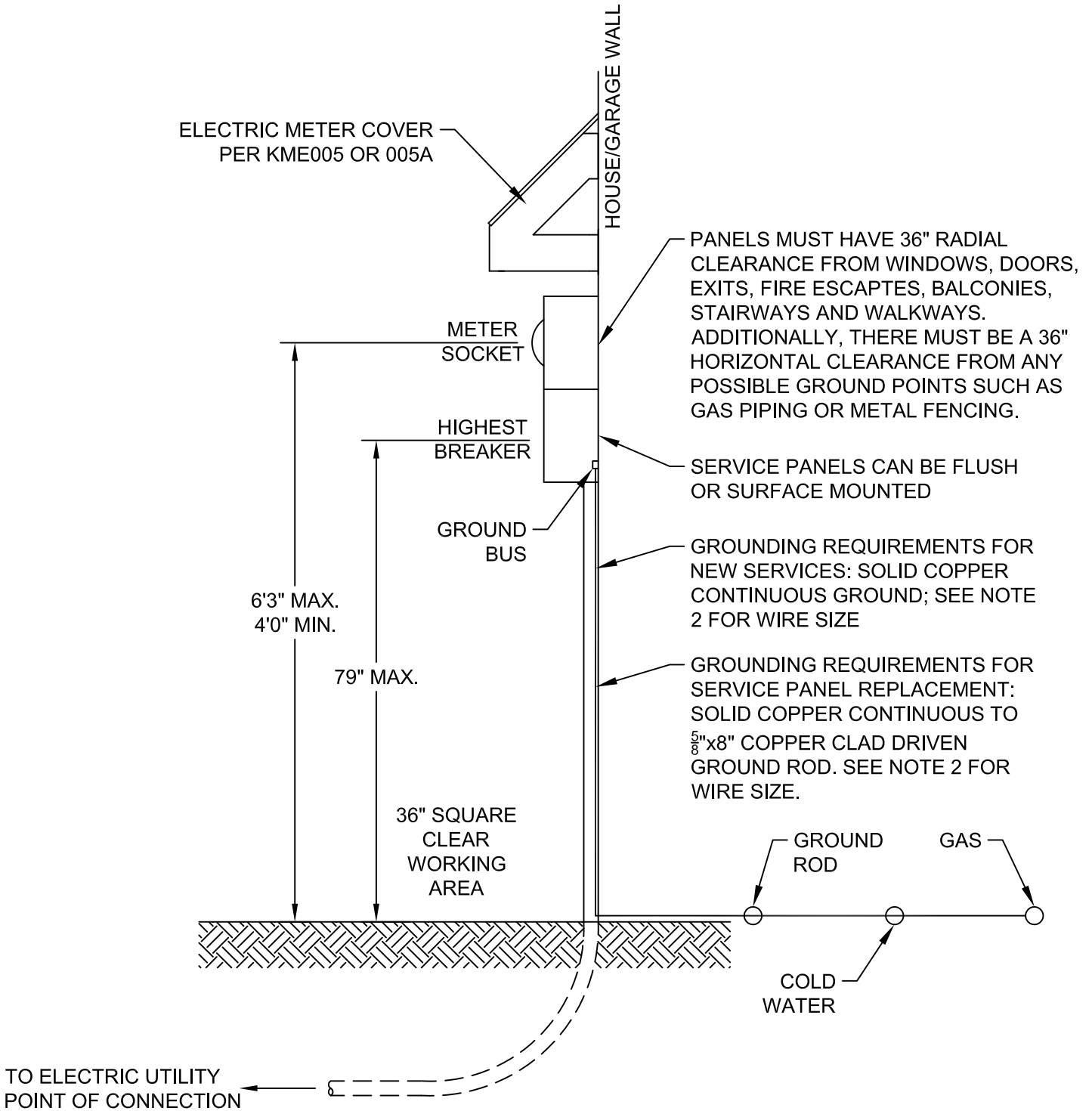

| | | |
|------------------------------------|---------------------|--------------------------------------|
| TYPICAL UNDERGROUND SERVICE | | |
| DATE: 5/5/22 | APPROVED BY: | DRAWING NUMBER: KME006 |
| SCALE: N.T.S. | DRAWN BY: L.P.B. | |

**SINGLE-PHASE
PADMOUNT TRANSFORMER**

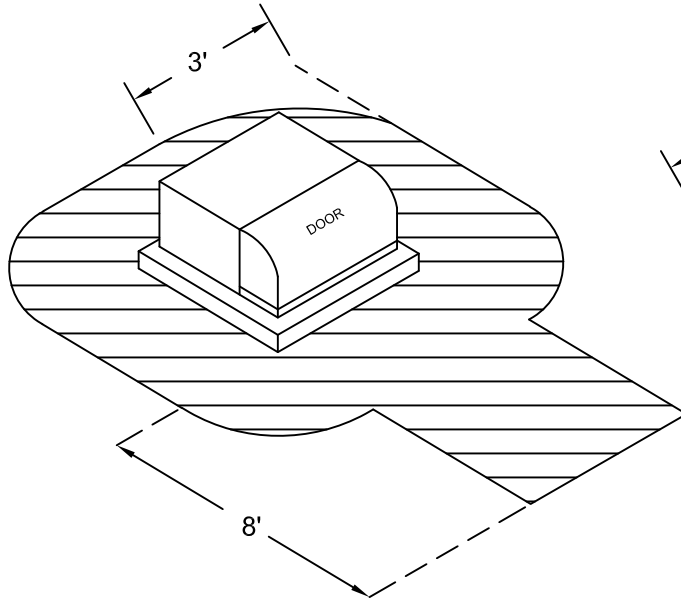

**THREE-PHASE
PADMOUNT TRANSFORMER**

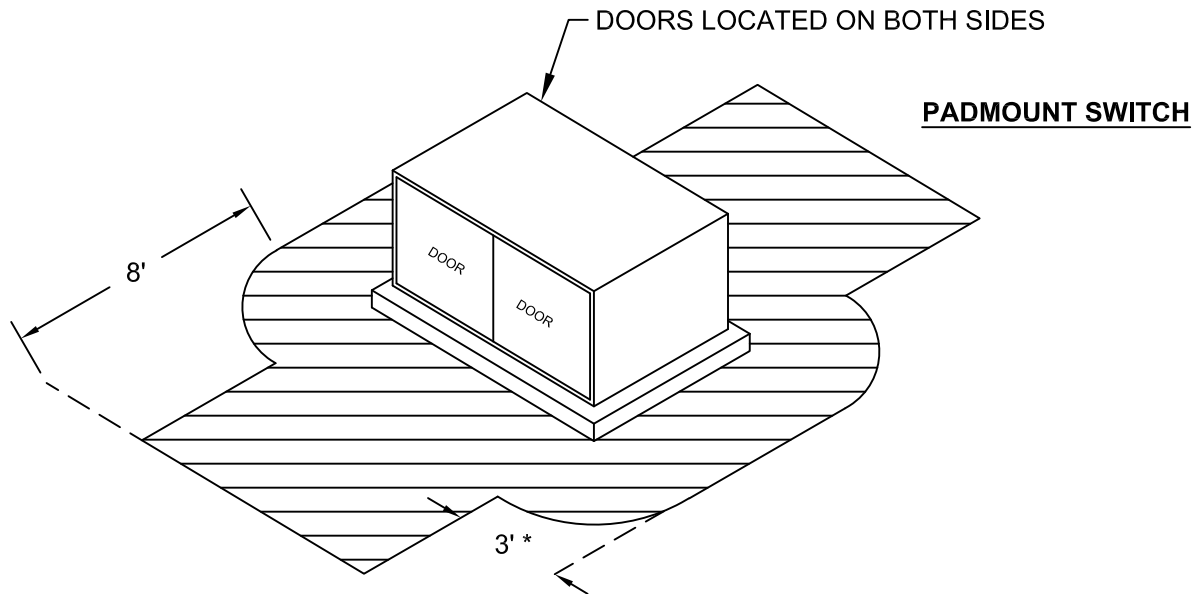
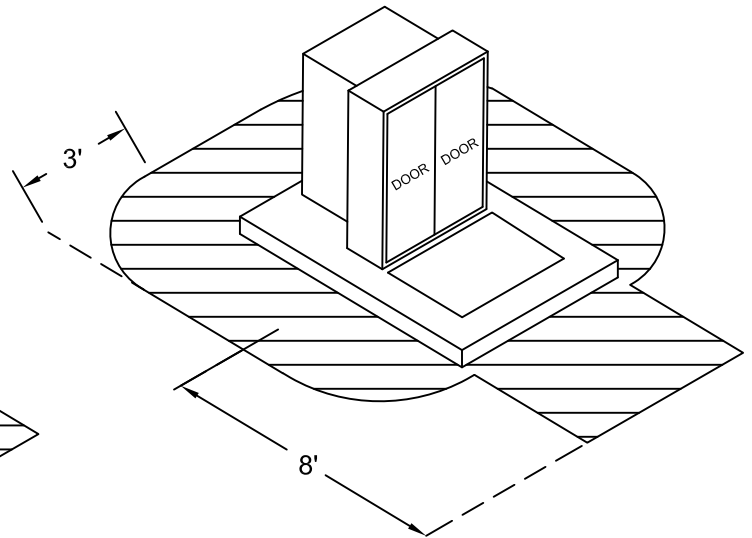

* INCREASE CLEARANCE WIDTH TO 5 FEET FOR ANY WET UTILITY STRUCTURE INCLUDING FIRE HYDRANTS, STAND PIPES, ABOVE GROUND WATER METERS AND BACKFLOW PREVENTORS.

NOTES:

1. ALL SIDES OF PADMOUNT EQUIPMENT MUST HAVE A MINIMUM OF 3 FEET RADIAL CLEARANCE. THIS CLEARANCE INCREASES TO 8 FEET FOR ANY SIDES WITH A DOOR. A PADMOUNT SWITCH HAS 2 SIDES WITH OPENING DOORS.
2. AREA AROUND PAD SHALL SLOPE AWAY FROM PAD AT A SLOPE NO GREATER THAN 2%. NO PERMANENT STRUCTURES OR LANDSCAPING ALLOWED WITHIN 5 FEET OF PAD.
3. CLEARANCES SHOWN SHALL BE KEPT AT ALL TIMES. KMPUD RESERVES THE RIGHT TO REMOVE ANY PLANTS, TREES, SHRUBS, ETC. THAT INTERFERE WITH WORKING CLEARANCES.



**CLEARANCE REQUIREMENTS FOR
PADMOUNT EQUIPMENT**

| | | |
|------------------|---------------------|--------------------------------------|
| DATE: 5/5/22 | APPROVED BY: | DRAWING NUMBER: KME007 |
| SCALE: N.T.S. | DRAWN BY: L.P.B. | |

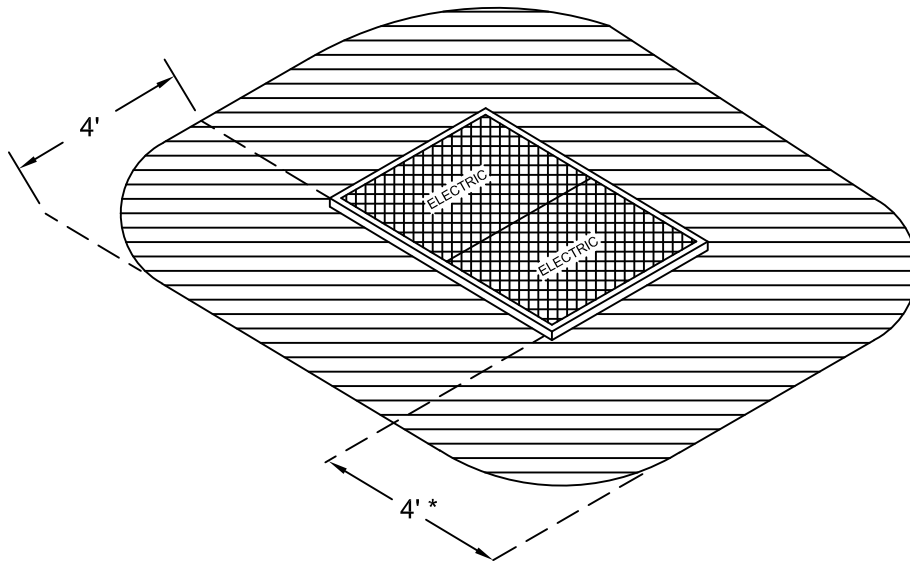

* INCREASE CLEARANCE WIDTH TO 5 FEET FOR ANY WET UTILITY STRUCTURE INCLUDING FIRE HYDRANTS, STAND PIPES, ABOVE GROUND WATER METERS AND BACKFLOW PREVENTORS.

NOTES:

1. ALL SIDES OF PADMOUNT EQUIPMENT MUST HAVE A MINIMUM OF 4 FEET RADIAL CLEARANCE.
2. AREA AROUND PAD SHALL SLOPE AWAY FROM PAD AT A SLOPE NO GREATER THAN 2%. NO PERMANENT STRUCTURES OR LANDSCAPING ALLOWED WITHIN 5 FEET OF PAD.
3. CLEARANCES SHOWN SHALL BE KEPT AT ALL TIMES. KMPUD RESERVES THE RIGHT TO REMOVE ANY PLANTS, TREES, SHRUBS, ETC. THAT INTERFERE WITH WORKING CLEARANCES.



MINIMUM CLEARANCE REQUIREMENTS FOR VAULTS

| | | |
|------------------|---------------------|--------------------------------------|
| DATE: 4/19/22 | APPROVED BY: | DRAWING NUMBER: KME008 |
| SCALE: N.T.S. | DRAWN BY: L.P.B. | |

TRANSFORMER PAD

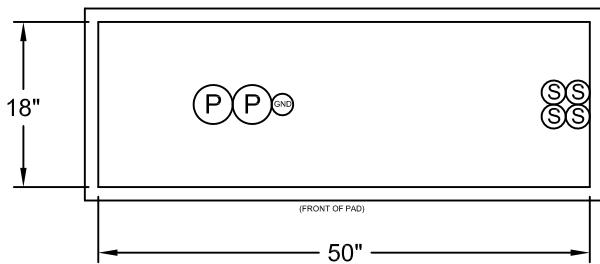
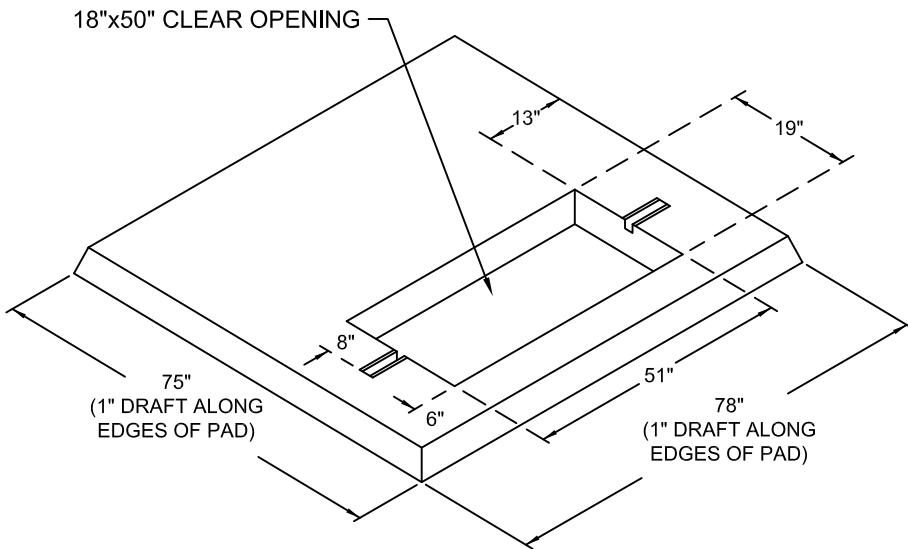

CONDUIT TOP VIEW

$\frac{5}{8}$ "x8" COPPER CLAD GROUND ROD

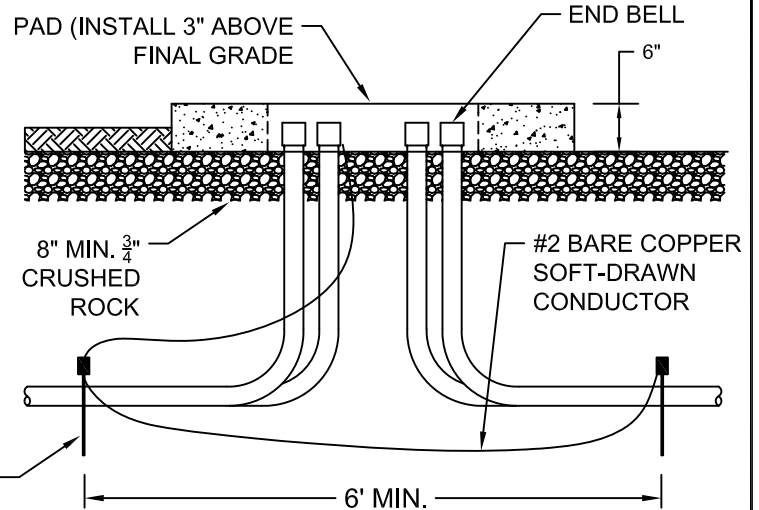

CONDUIT SIDE VIEW

NOTES:

1. LOCATE PAD AS DIRECTED BY KMPUD.
2. INSTALL GROUNDING SYSTEM PER "SIDE VIEW" DETAIL. GROUND WIRE MUST BE #2 BARE COPPER SOFT-DRAWN CONDUCTOR. LEAVE 10 FEET OF GROUND WIRE SLACK FOR TRANSFORMER CONNECTION. USE EXOTHERMIC WELDING TO MAKE ALL CONNECTIONS. COMPRESSION CONNECTORS MAY BE USED ONLY WHEN COMPLETED BY KMPUD.
3. INSTALL A MINIMUM OF 8 INCHES OF $\frac{3}{4}$ " CRUSHED ROCK UNDERNEATH THE PAD.
4. INSTALL END BELLS AND EXPANDABLE RUBBER PLUGS ON EACH EXPOSED CONDUIT. PRIMARY AND SECONDARY CONDUITS MUST BE GROUPED TOGETHER ON OPPOSITE SIDES PER DETAIL ABOVE.
5. INSTALL A TEMPORARY BOLT-DOWN $\frac{5}{8}$ " PLYWOOD COVER ABOVE PAD OPENING IMMEDIATELY AFTER COMPLETING PAD INSTALLATION.
6. IF REQUIRED BY KMPUD, INSTALL PROTECTIVE BARRIERS PER KMW007B.
7. PROVIDE UNOBSTRUCTED SPACE CLEARANCES AROUND PAD PERIMETER PER OTHER APPLICABLE DETAILS.
8. IN SOFT SOILS AND AT DISCRETION OF KMPUD, 2 SACK SAND SLURRY MAY BE REQUIRED UNDER THE PAD. SLURRY MUST BE 12" DEEP AND EXTEND 12" BEYOND EACH PAD EDGE.
9. PROVIDE FIVE (5) ONE-INCH LIFTING INSERTS ON PAD, ONE (1) ON EACH SIDE AND ONE (1) ON TOP.



THREE-PHASE PRECAST CONCRETE TRANSFORMER PAD

| | | |
|------------------|---------------------|-----------------|
| DATE: 4/19/22 | APPROVED BY: | DRAWING NUMBER: |
| SCALE: N.T.S. | DRAWN BY: L.P.B. | KME009 |

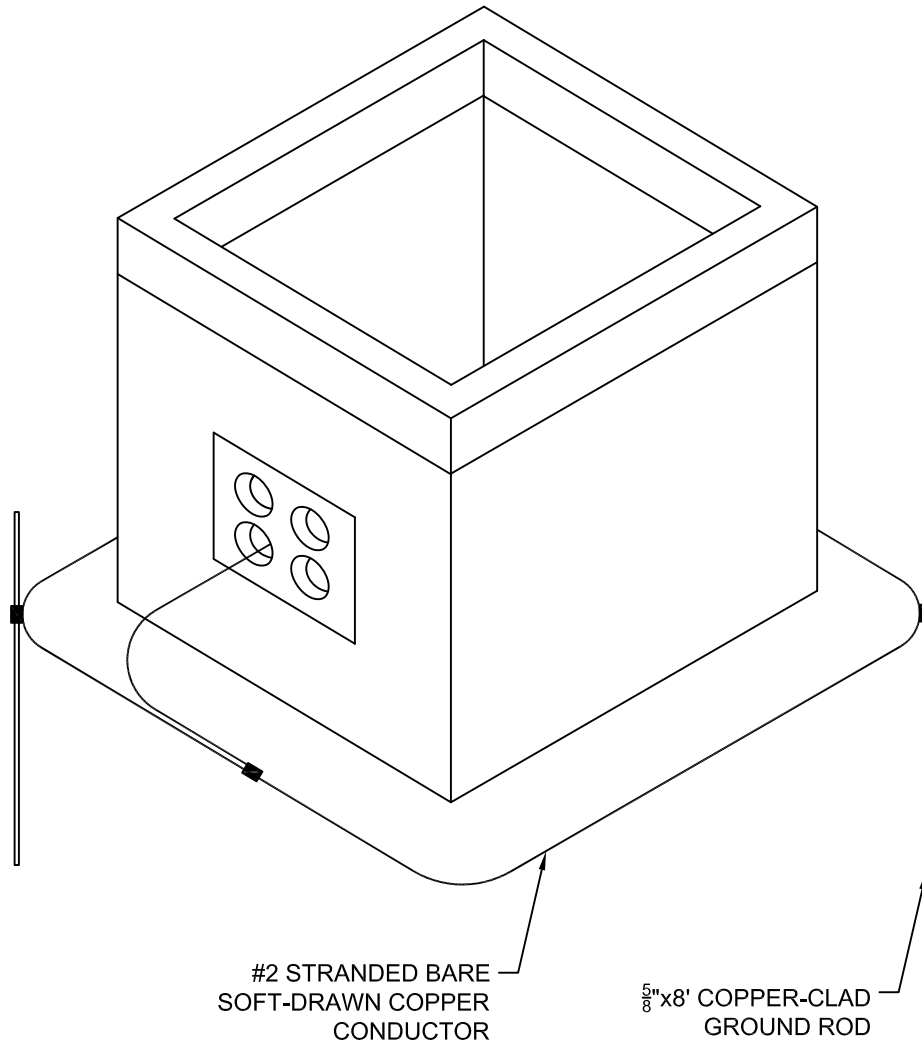

NOTES:

1. INSTALL A LOOP AROUND THE VAULT USING #2 STRANDED BARE SOFT-DRAWN COPPER CONDUCTOR.
2. INSTALL (2) $\frac{5}{8}$ "x8' COPPER-CLAD GROUND RODS AT OPPOSITE EXTERIOR CORNERS OF VAULT.
3. USE EXOTHERMIC WELDING TO MAKE ALL CONNECTIONS.
4. COMPRESSION CONNECTORS MAY BE USED ONLY WHEN KMPUD MAKES COMPRESSION CONNECTION.
5. INSERT GROUND WIRE INTO SPARE KNOCKOUT AS SHOWN UNLESS OTHERWISE DIRECTED BY KMPUD.
6. LEAVE ENOUGH GROUND WIRE SLACK INSIDE VAULT TO WRAP AROUND ITS ENTIRE INTERIOR PERIMETER.



GROUNDING REQUIREMENTS FOR PRECAST CONCRETE VAULTS

| | | |
|------------------|---------------------|--------------------------------------|
| DATE: 4/19/22 | APPROVED BY: | DRAWING NUMBER: KME011 |
| SCALE: N.T.S. | DRAWN BY: L.P.B. | |

NOTES:

1. LOCATE VAULT AS DIRECTED BY KMPUD.
2. VAULT DETAIL IS INTENDED TO ILLUSTRATE A TYPICAL LAYOUT OF REQUIRED EQUIPMENT & CLEARANCES. THIS DETAIL IS NOT INTENDED FOR CONSTRUCTION PURPOSES. VAULT DESIGN SUBJECT TO KMPUD APPROVAL.
3. PIT SUMP SHALL DRAIN TO DAYLIGHT OR TO A GRAVEL SUMP LOCATED A MINIMUM 10 FEET AWAY FROM VAULT THROUGH A 4" DIA. DRAIN PIPE OR HAVE SOME OTHER POSITIVE MEANS OF DRAINAGE SUCH AS A SUMP PUMP OR EDUCTOR.
4. INSTALL A MINIMUM OF 8" OF CRUSHED ROCK UNDER VAULT.
5. PROVIDE UNOBSTRUCTED CLEARANCES AROUND VAULT PER OTHER APPLICABLE DETAILS.

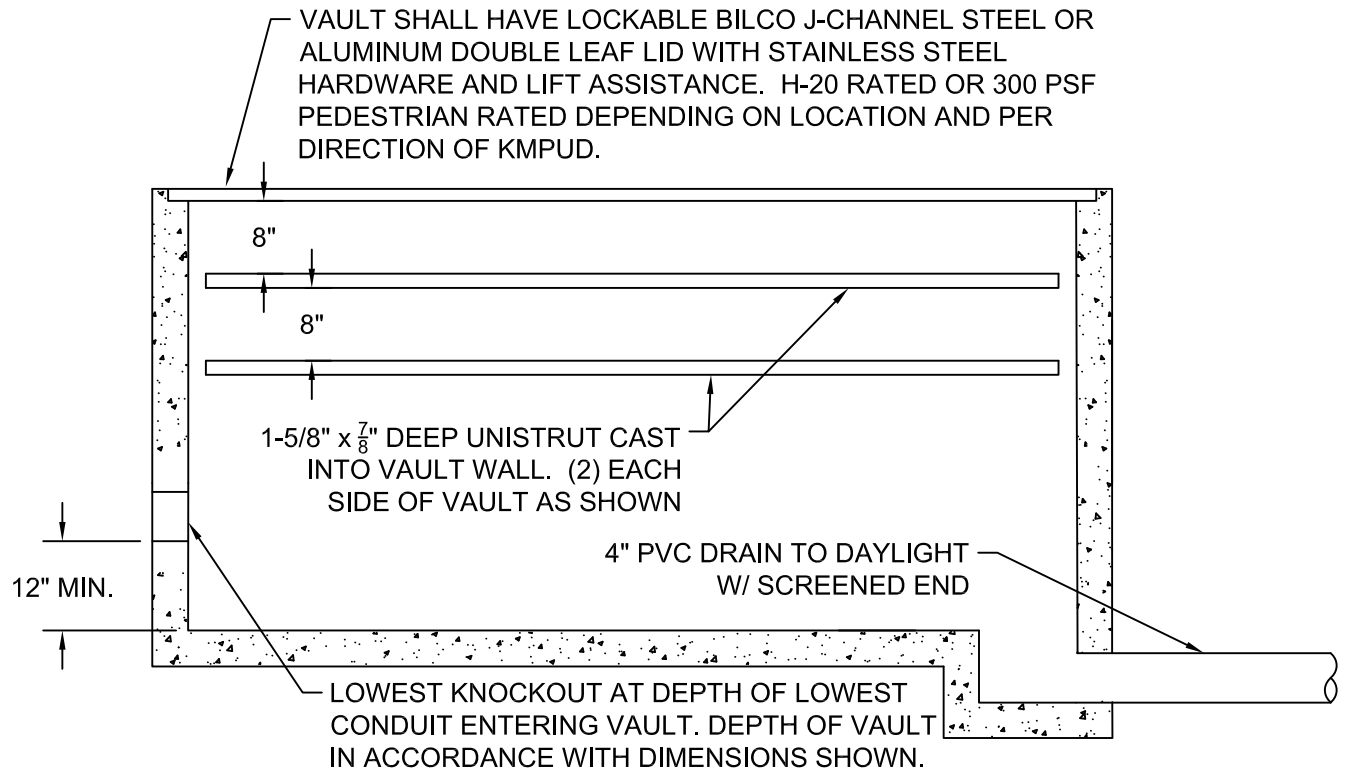
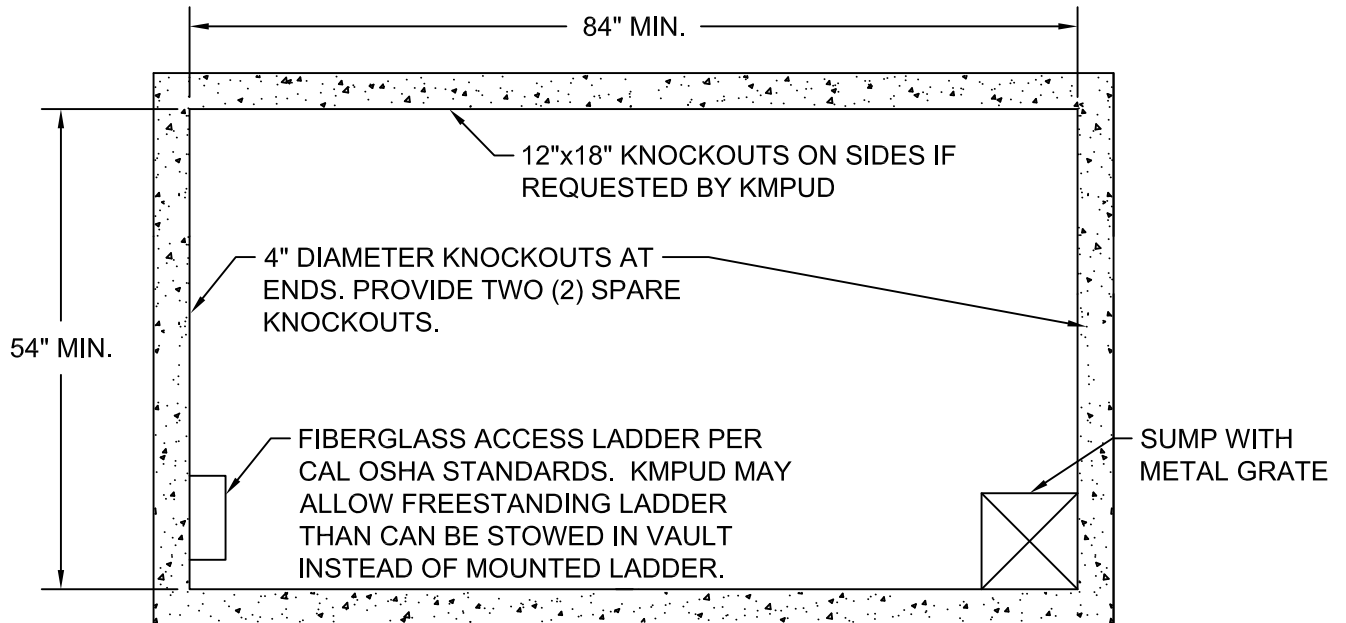

**PRECAST CONCRETE
VAULT LAYOUT**



| | | |
|------------------|------------------------|--------------------------------------|
| DATE: 5/2/22 | APPROVED BY: E.M.C. | DRAWING NUMBER: KME012 |
| SCALE: N.T.S. | DRAWN BY: L.P.B. | |

| | | | | | |
|-------|--------|-------|------------|-----------|-------------|
| DIST. | COUNTY | ROUTE | POST MILE | SHEET NO. | TOTAL SHEET |
| 10 | AMA | 88 | 51.5-71.36 | 40 | 76 |

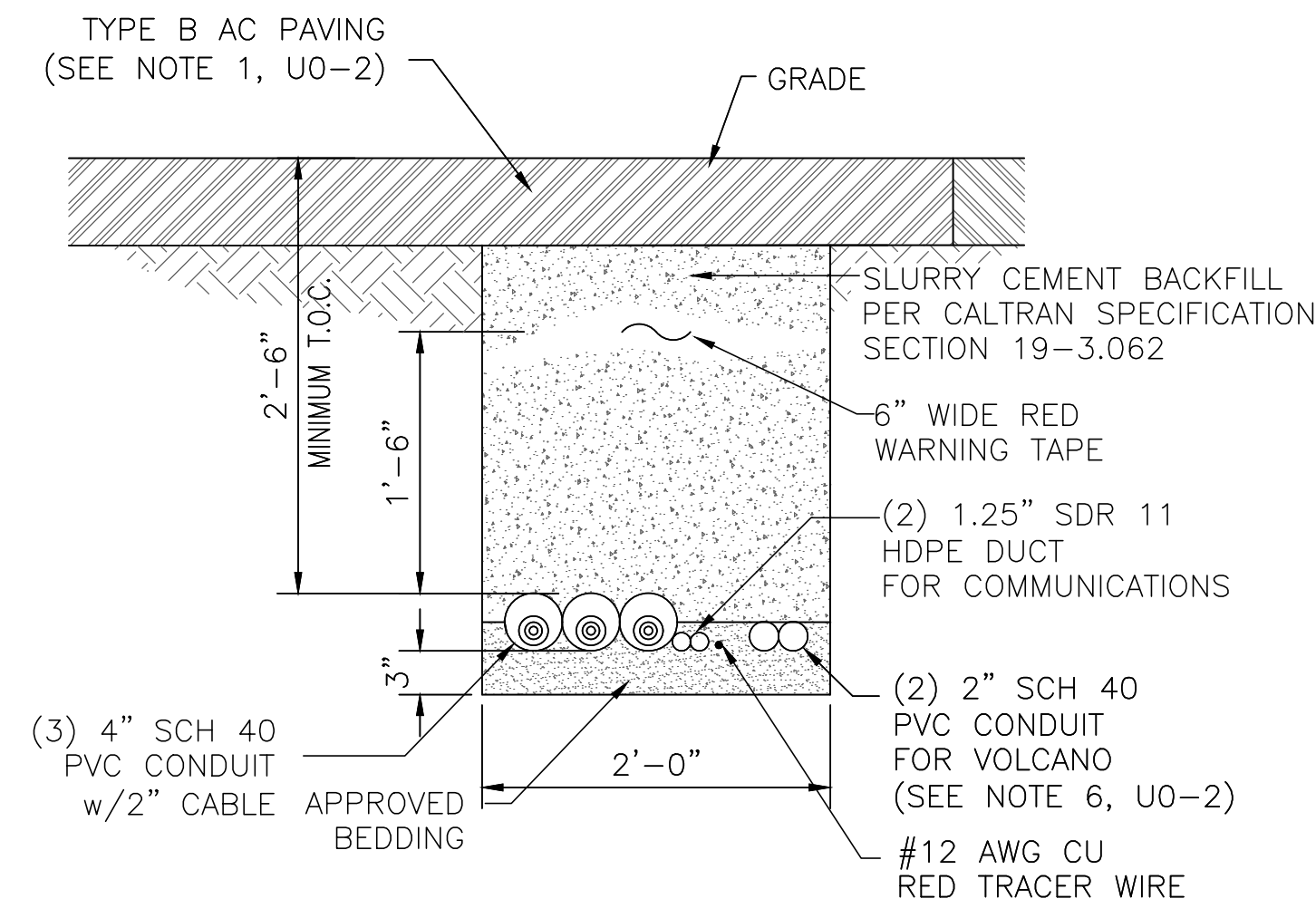

TYPICAL 4" CONDUIT IN PAVED ROAD INSTALLATION DETAIL (A)
 NTS
 SEE NOTE 17, U0-2
 SEE NOTE 18, U0-2
 FOR AMADOR COUNTY ROAD
 SEE TYPICAL DETAIL, U0-2

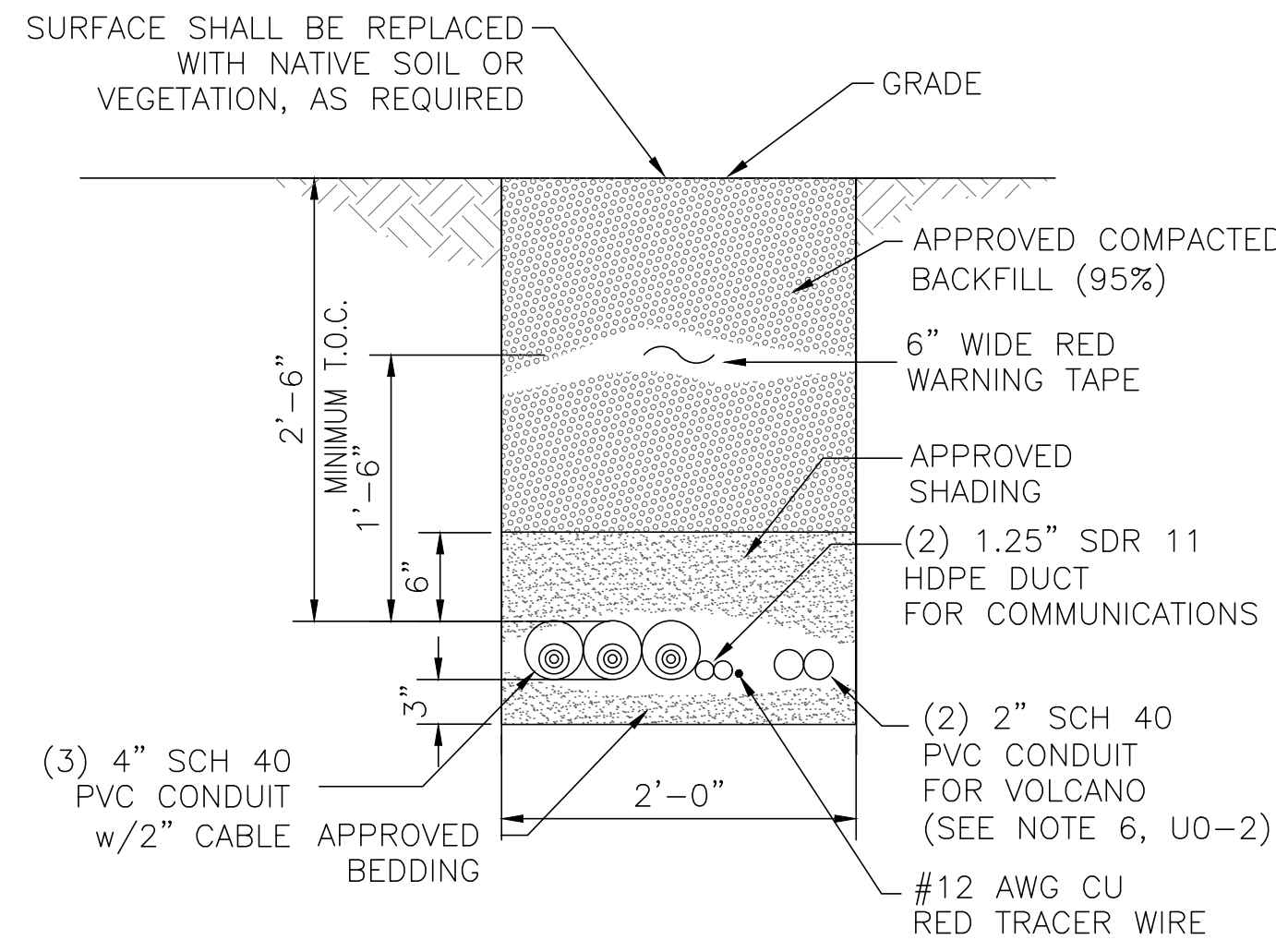

TYPICAL 4" CONDUIT IN ROAD ROW NOT WITHIN ROAD PRISM INSTALLATION DETAIL (B)
 NTS

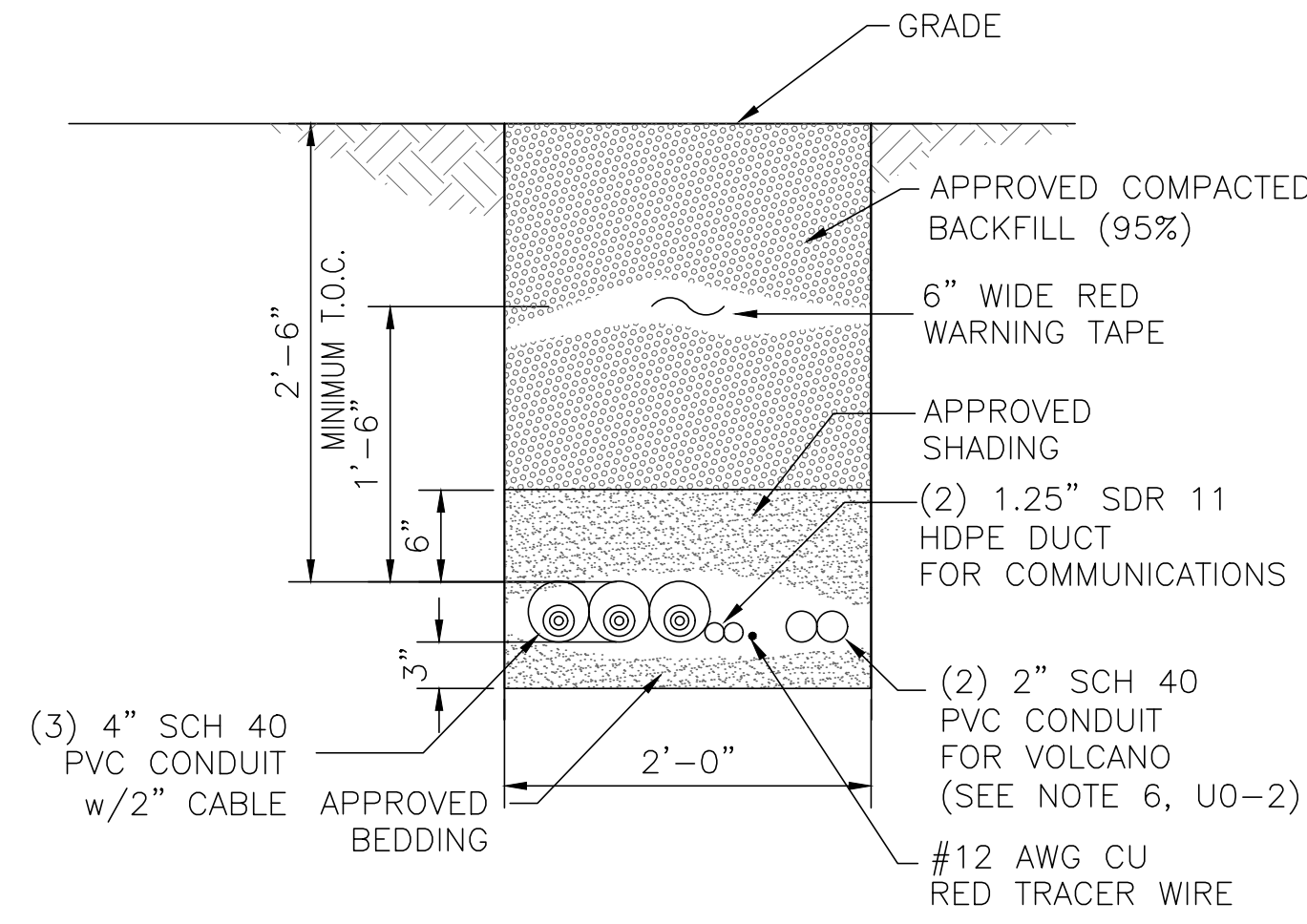

TYPICAL 4" CONDUIT INSTALLATION DETAIL (C)
 NTS

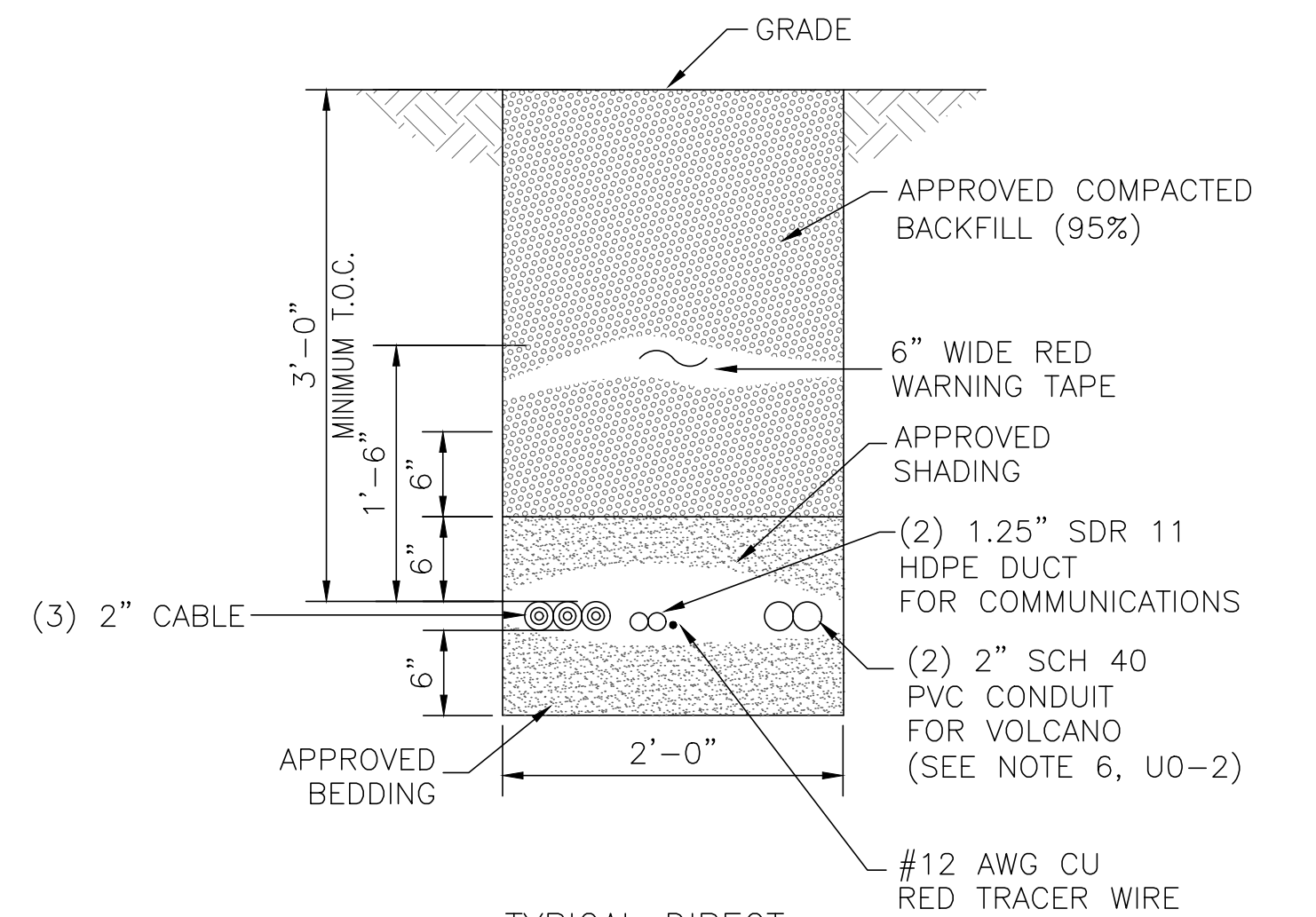

TYPICAL DIRECT BURIED INSTALLATION DETAIL (D)
 NTS

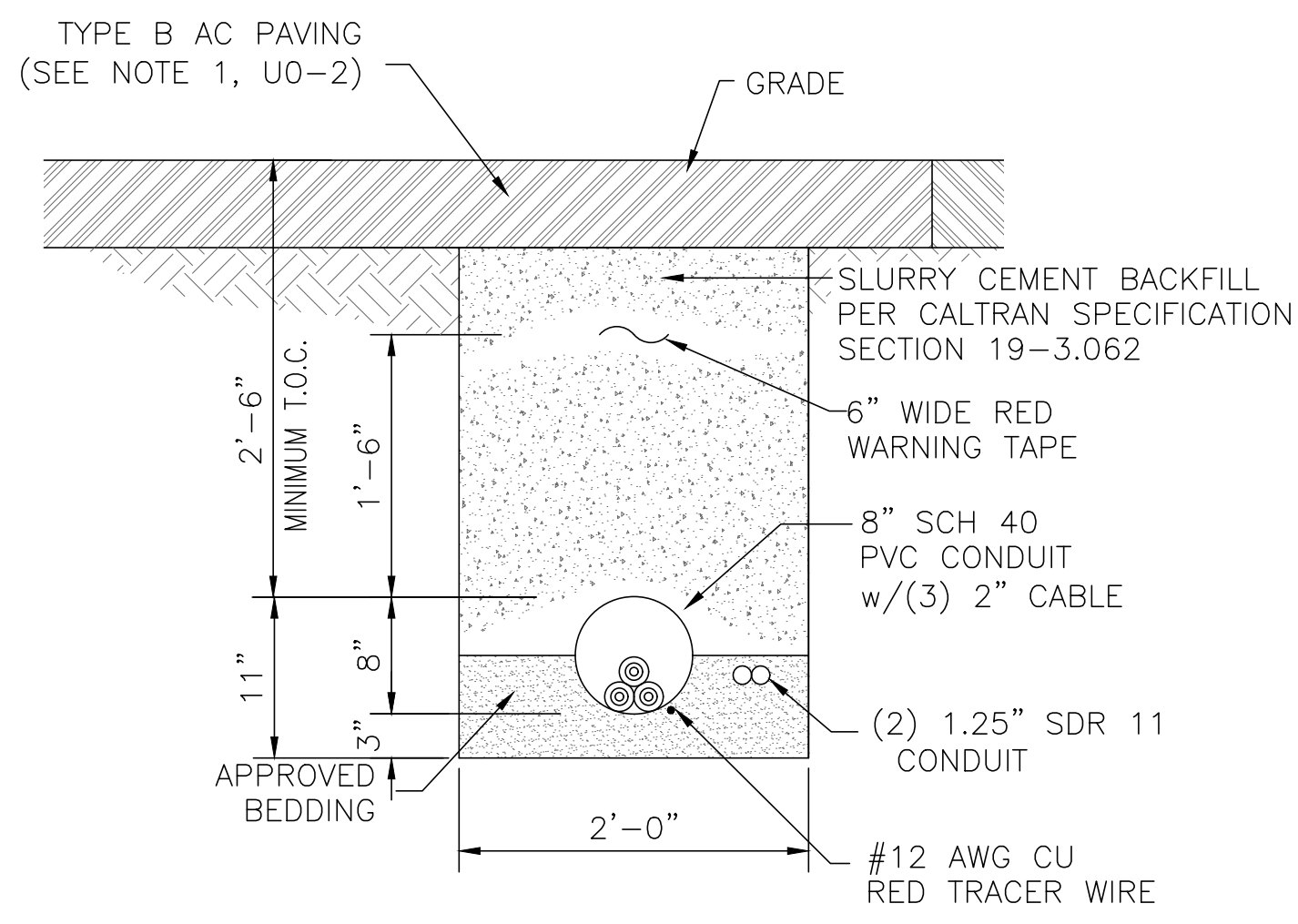

TYPICAL 8" CONDUIT IN PAVED ROAD INSTALLATION DETAIL (E)
 NTS

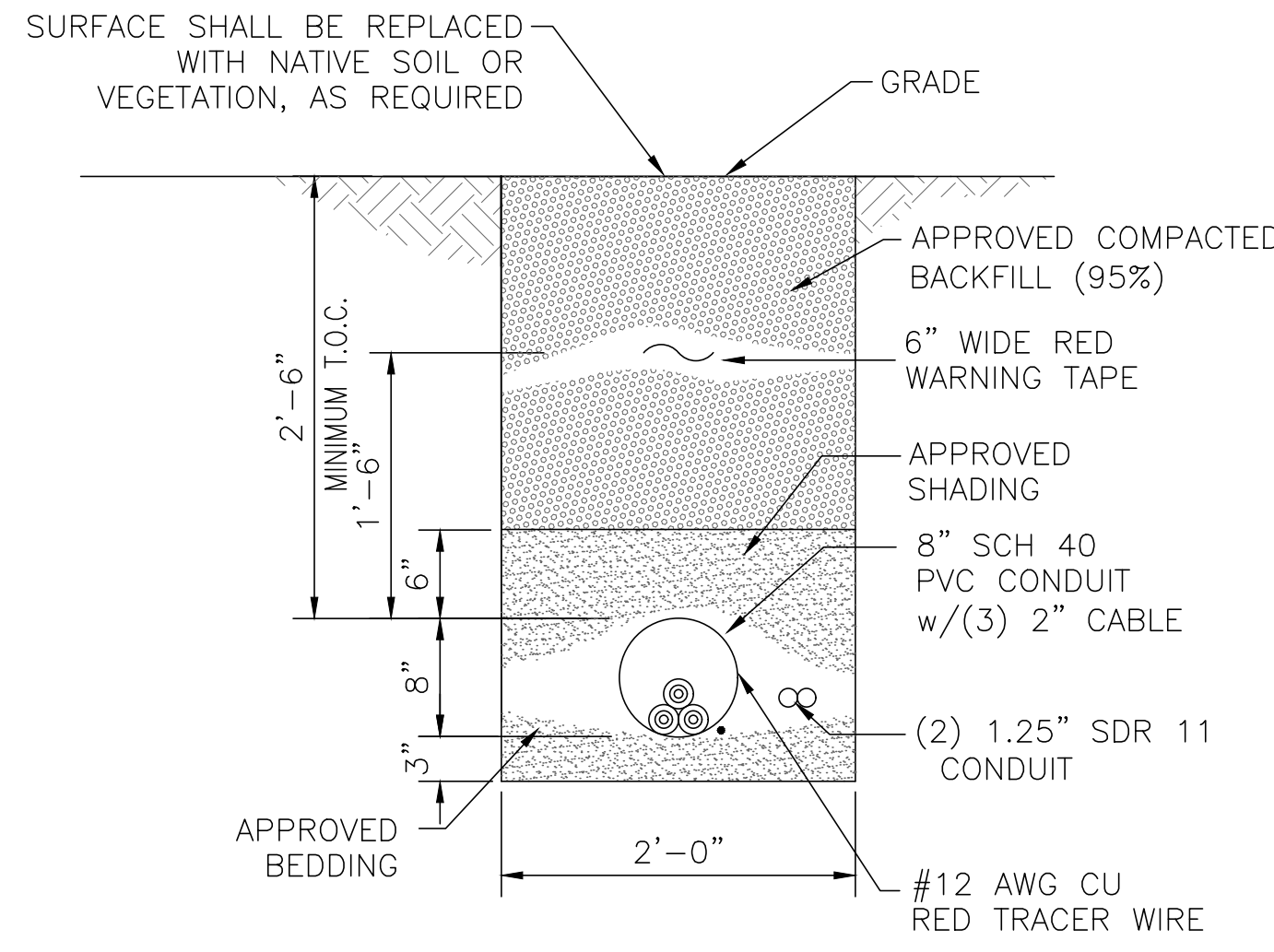

TYPICAL 8" CONDUIT IN ROAD ROW NOT WITHIN ROAD PRISM INSTALLATION DETAIL (F)
 NTS

NOT USED (G)
 NTS

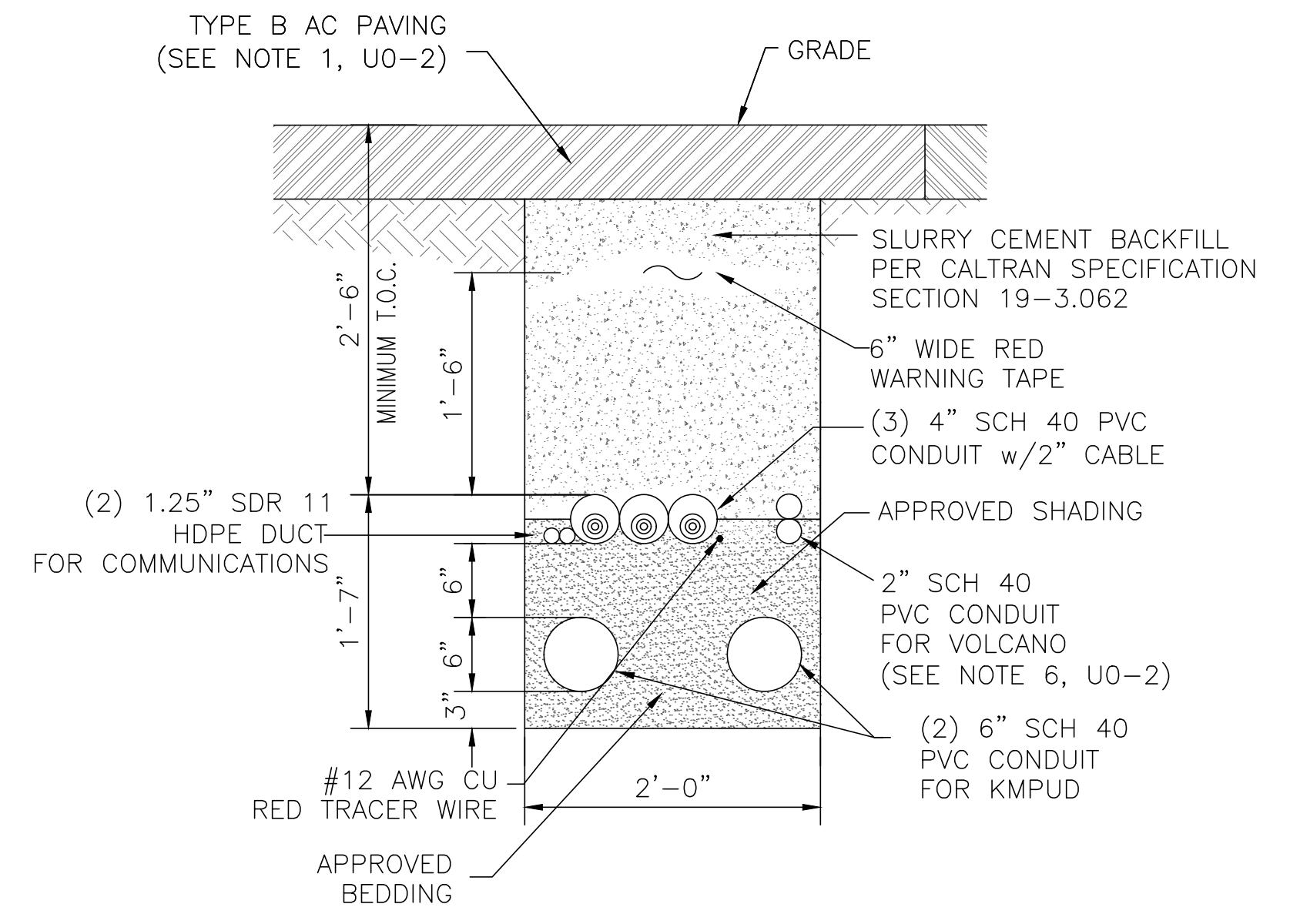

S.R. 88 CROSSING INSTALLATION DETAIL (H)
 NTS

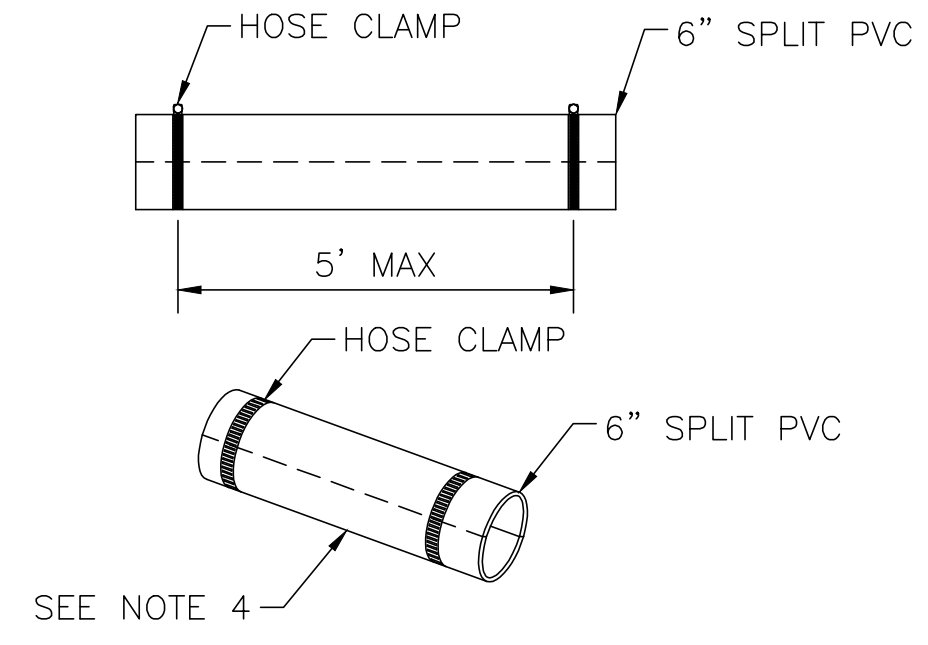

SPLIT PVC DETAIL
 NTS

UNDERGROUND-U0-1.dwg

Exponential Engineering Company
 328 Airpark Drive
 Fort Collins, Colorado 80524
 Phone: (970) 207-9648
 Fax: (970) 207-9657
 Thomas A. Ghidossi, P.E.
 #E17176

| REV | REVISIONS | DATE | DRN | DSGN | CKD | APPD | REFERENCE DRAWINGS |
|-----|-------------------------------------|----------|-----|------|-----|------|--------------------|
| 2 | ISSUE FOR RECORD DRAWINGS | 05-08-15 | NRB | WEM | DHR | TAG | |
| 1 | RE-ISSUE FOR CONSTRUCT.-ALL DETAILS | 08-20-13 | NRB | WEM | DHR | TAG | |
| 0 | ISSUE FOR CONSTRUCTION | 05-17-13 | NRB | WEM | DHR | TAG | * * |

| | | |
|--------------------|----------|----------|
| DSGN | WEM | 02-25-13 |
| DRN | NRB | 02-25-13 |
| CKD | DHR | 02-25-13 |
| SCALE: | AS SHOWN | |
| FOR 24x36 DWG ONLY | | |

| | | |
|-----------------------|----------------|------------|
| KIRKWOOD MEADOWS PUD | JOB NUMBER | KMPUD 1301 |
| 35kv UNDERGROUND LINE | DRAWING NUMBER | U0-1 |
| TYPICAL SECTIONS | | |